

# Principles of dilution refrigeration

A brief technology guide



OXFORD  
INSTRUMENTS

*The Business of Science®*



## About the authors

### Dr Graham Batey

Chief Technical Engineer  
United Kingdom



Graham completed his PhD in Low Temperature Physics at Nottingham University in 1985 and joined Oxford Instruments designing top loading plastic dilution refrigerators to run in pulsed magnets, a rotating dilution refrigerator, and dark matter systems installed deep underground. He was involved in designing Oxford Instruments' **Kelvinox™** range of dilution refrigerators and the world's leading cryogen free range of dilution refrigerators – **Triton™**, which in 2010 received the Queen's award for innovation. In 2011, Graham received 'The Business & Innovation' award from the Institute of Physics and was elected Fellow of the IOP.

### Dr Gustav Teleberg

ULT Product Manager  
Sweden



Gustav Teleberg gained his PhD in cryogenics for astronomy at Cardiff University where he developed miniature dilution refrigerators and heat switches for telescope applications. He joined Oxford Instruments in 2007 as a Cryogenic Engineer where he worked on developing the Cryofree® dilution refrigerator that today is known as **Triton™**. He also worked on several patented technologies for rapid sample exchange and heat pipes for accelerated cooling.

# Principles of dilution refrigeration

By Graham Batey and Gustav Teleberg

Published by: Oxford Instruments NanoScience  
Tubney Woods, Abingdon, Oxon, OX13 5QX, United Kingdom,  
Telephone: +44 (0) 1865 393200  
Email: [nanoscience@oxinst.com](mailto:nanoscience@oxinst.com)  
[www.oxford-instruments.com/nanoscience](http://www.oxford-instruments.com/nanoscience)

© Oxford Instruments Nanotechnology Tools Limited, 2015. All rights reserved.



*The Business of Science®*



## History

The dilution refrigerator was first proposed by Heinz London in the early 1950s, and was realised experimentally in 1964 at Leiden University. In 1965, Henry Hall built the first  $^3\text{He}$ - $^4\text{He}$  dilution refrigerator at University of Manchester. The first commercial dilution refrigerator was developed in collaboration with Heinz London at the Oxford Instruments factory in Osney Mead, Oxford in 1967. The achieved 200 mK base temperature enabled dilution cooling beyond known  $^3\text{He}$  temperatures.

The dilution refrigerator has evolved over its 50 years with improved performance, reliability and  $^3\text{He}$  efficiency. Today, temperatures below 4 mK can be achieved with the push of a button and without the use of any external liquid helium cooling.



Sir Martin Wood with the mixing chamber of the first commercial dilution refrigerator, built at Oxford Instruments



First commercial dilution refrigerator insert



Early 70's dilution unit with copper heat exchanger



Modern dilution unit with silver heat exchanger





Gravitational wave detector - photo courtesy of Gran Sasso, University of Rome



High magnetic field laboratory - photo courtesy of Bristol University



Centre for quantum devices - photo courtesy of Niels Bohr Institute, Copenhagen



D-Wave quantum processor - photo courtesy of D-Wave Systems

Over the years, dilution refrigerators have been used for cooling anything from millimeter-sized semiconductors to 3 ton gravitational wave detectors, down to milliKelvin (mK) temperatures. Superconducting magnets with field strengths of up to 50 Tesla (T) have been combined with these refrigerators for the study of novel superconductors. Currently, dilution refrigerators are used by scientists trying to realise quantum computers, searching for the hypothesised Majorana particle, and in the study of many other novel quantum properties.

## 4 K technology

- All dilution refrigerators rely on a stable cold environment at approximately 4 K. Until recently, this has meant a liquid helium bath with a boiling point of 4.2 K at atmospheric pressure
- Now, it is more common to use a pulse tube cooler which greatly simplifies operation and is less costly to operate
- A two-stage pulse tube cooler typically provides 50 W of cooling power at 70 K on its first stage and 1 – 1.5 W at 4 K on its second stage. The power consumption of its compressor is typically 9 kW
- 'Dry' dilution refrigerators based on pulse tube technology now account for 90% of all systems sold. 'Wet' systems are still used but mainly at the extremes of vibration sensitive applications, such as STM



## Evaporative cooling of $^4\text{He}$

We start by describing the principle of evaporative cooling as this is essential also for dilution refrigeration:

- A small amount of liquid helium from the main bath continuously feeds a 'pot' (below left)
- A pump is used to reduce the pressure inside the pot to typically 0.1 mbar
- Cooling is achieved due to the latent heat of the evaporated liquid
- The lowest achievable temperature is limited by the exponentially decreasing vapour pressure. At low enough pressure there are simply not enough molecules to cool the pot further
- Pumping on liquid  $^4\text{He}$  is the easiest method to achieve around 1.2 K. This is already colder than outer space (2.7 K)
- Temperatures down to around 0.25 K can be achieved by pumping on liquid  $^3\text{He}$  instead, since it has much higher vapour pressure than  $^4\text{He}$

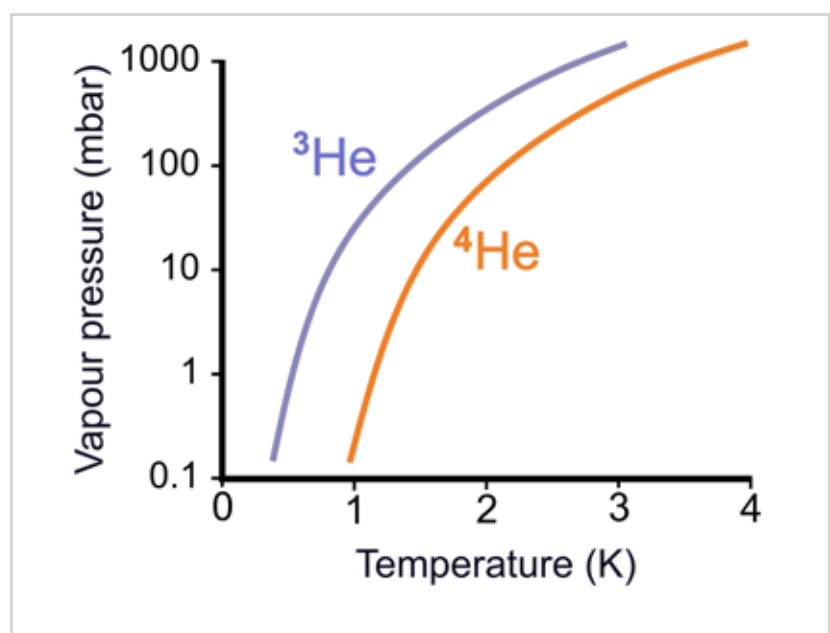
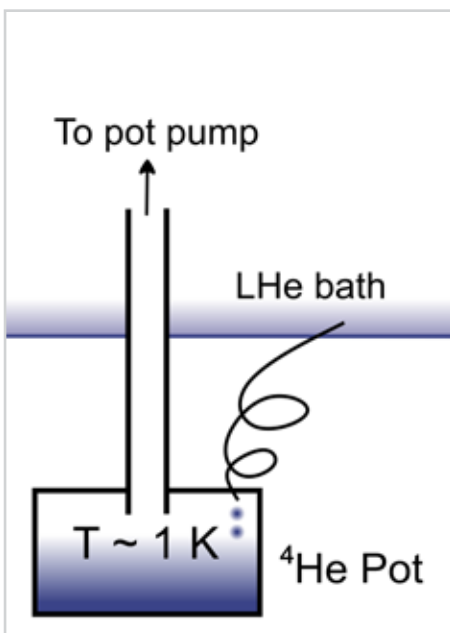

## $^3\text{He}$ vs $^4\text{He}$

### How is liquid $^3\text{He}$ different to liquid $^4\text{He}$ ?

- $^3\text{He}$  is lighter than  $^4\text{He}$  which means the binding energy between the atoms in the liquid is weaker. This results in a lower latent heat of evaporation
- The lower latent heat of  $^3\text{He}$  results in a higher vapour pressure ( $p$ ) since:  $p \propto \exp(-L/RT)$
- $^3\text{He}$  consists of 3 nucleons ( $L$ ), which makes it a Fermion while  $^4\text{He}$  with 4 nucleons is a Boson. As we shall see, this difference is fundamental for dilution refrigeration

### Where does $^3\text{He}$ come from?

- While  $^4\text{He}$  can easily be extracted from natural underground reserves,  $^3\text{He}$  is a much rarer isotope which is produced as a by-product from nuclear reactions (tritium decay or deuterium-deuterium fusion reaction)
- The majority of all  $^3\text{He}$  gas available is used for security detector applications
- Approximately 10% is used for ultra low temperatures applications

## $^3\text{He}$ - $^4\text{He}$ mixtures

- Pure  $^4\text{He}$ , with a nuclear spin of  $I = 0$ , obeys Boson statistics and undergoes a transition to superfluid at 2.17 K
- Pure  $^3\text{He}$ , with a nuclear spin of  $I = 1/2$ , obeys Fermi statistics and the Pauli Exclusion principle which prevents  $^3\text{He}$  from undergoing a superfluid transition until much lower temperatures at which the spins pair up and then obey Boson statistics
- The superfluid transition temperature of a  $^3\text{He}$  -  $^4\text{He}$  mixture depends on the  $^3\text{He}$  concentration as in the figure below left
- Say we start with a mixture at a concentration and temperature at point A. When this is cooled down to the temperature at point B, it undergoes a superfluid transition. If we cool the mixture further to point C, it separates into two phases with the  $^3\text{He}$ -rich phase floating on top of the heavier  $^4\text{He}$ -rich phase (below right)
- The  $^4\text{He}$ -rich phase (the 'dilute' phase) contains 6.4%  $^3\text{He}$  all the way down to 0 K. This finite solubility of  $^3\text{He}$  in  $^4\text{He}$  is the key to dilution refrigeration

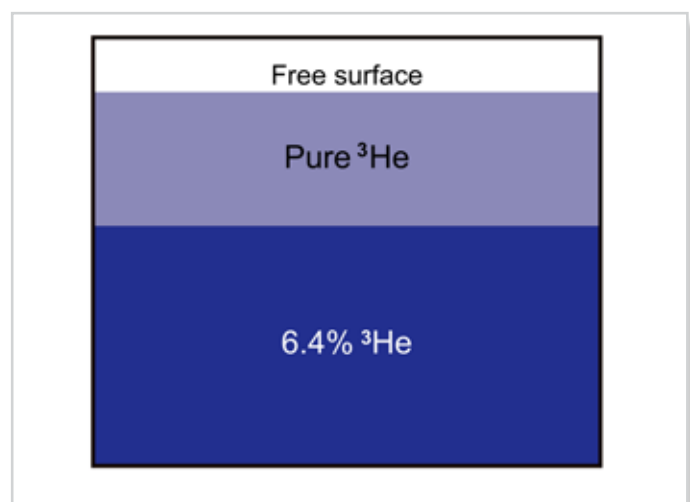
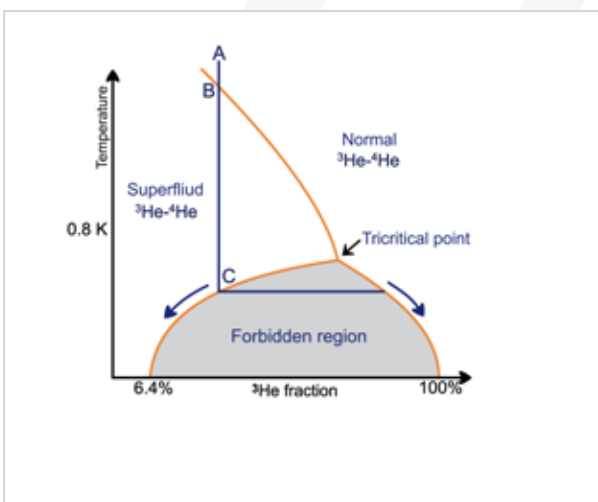

## Finite solubility of $^3\text{He}$ in $^4\text{He}$ explained

Imagine we could cool two containers of pure  $^3\text{He}$  and pure  $^4\text{He}$  separately to 0 K before they are allowed to interact. The first  $^3\text{He}$  atom to venture across the boundary will consider whether to stay in the  $^4\text{He}$  environment or to go back.

- $^3\text{He}$  is the lighter of the two isotopes. This means it has a larger zero-point motion, in other words it will occupy a larger volume
- The  $^3\text{He}$  atom will find itself closer to surrounding  $^4\text{He}$  atoms than to surrounding  $^3\text{He}$  atoms
- Because the binding between the atoms is due to van der Waals forces, the shorter distance results in  $^3\text{He}$  being more strongly bound in  $^4\text{He}$  than in pure  $^3\text{He}$
- Since the  $^3\text{He}$  atom is more strongly bound in  $^4\text{He}$  it will 'prefer' to stay in the  $^4\text{He}$  liquid. This is the reason for the finite solubility at 0 K
- To understand why the finite solubility is 6.4%, we need to look in more detail at the binding energy. Consider the chemical potential  $\mu$  of  $^3\text{He}$  in  $^4\text{He}$  and let's say the binding energy of a single  $^3\text{He}$  atom in  $^4\text{He}$  is  $\epsilon$
- The binding energy of  $^3\text{He}$  in  $^3\text{He}$  is equal to the latent heat of evaporation of pure  $^3\text{He}$ ,  $L$ , so  $\epsilon$  must be greater than  $L$  as shown in the figure below right
- The first two  $^3\text{He}$  atoms will occupy the lowest energy state  $-\epsilon$  with anti-parallel spins
- Additional  $^3\text{He}$  atoms have to obey the Pauli Exclusion principle and therefore occupy increasingly higher energy states (described by the wave function solutions to the Schrodinger equation of a 'particle in a box')
- The Fermi energy  $k_B T_F$  will increase with the He concentration  $x$ , as shown in the figure
- At a concentration of 6.4%, the chemical potential equals that of a  $^3\text{He}$  atom in pure  $^3\text{He}$ . This is therefore the finite solubility of  $^3\text{He}$  in  $^4\text{He}$  at 0 K

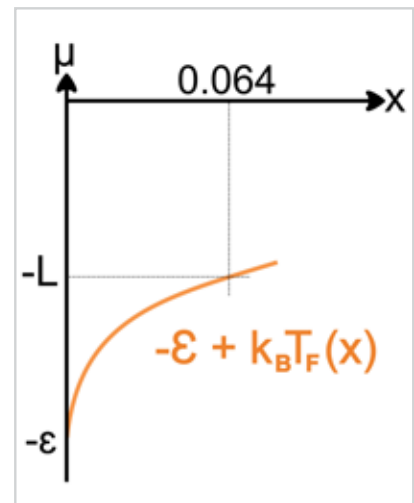



## Cooling power of the dilution process

- If we can remove  $^3\text{He}$  atoms from the diluted phase,  $^3\text{He}$  atoms from the concentrated phase will cross the phase boundary to occupy the vacant energy states
- The associated cooling power is then given by the enthalpy difference  $\Delta H$  between  $^3\text{He}$  in diluted  $^4\text{He}$  and pure  $^3\text{He}$  multiplied by the  $^3\text{He}$  flow rate:

$$\dot{Q} = \dot{n}_3 \Delta H = 84 n_3 T^2$$

- The enthalpy of  $^3\text{He}$  in  $^4\text{He}$  is higher than for pure  $^3\text{He}$  due to  $^3\text{He}$  in  $^4\text{He}$  behaving as a Fermi gas. This is analogous to the enthalpy difference between  $^3\text{He}$  gas and  $^3\text{He}$  liquid that results in cooling power in an evaporation refrigerator
- In reality the returning  $^3\text{He}$  is always slightly warmer than the outgoing  $^3\text{He}$  due to non-ideal heat exchangers. A more accurate cooling power expression therefore takes into account the temperature of the mixing chamber ( $T_{mc}$ ) as well as the temperature of the last heat exchanger ( $T_{ex}$ ):

$$\dot{Q} = \dot{n}_3 (95 T_{mc}^2 - 11 T_{ex}^2)$$

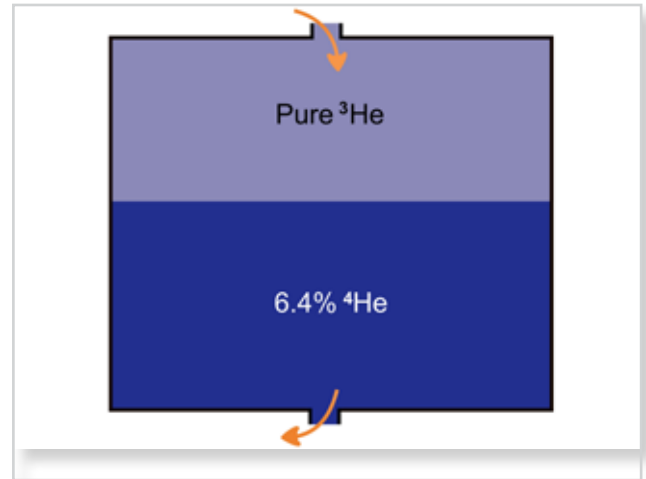

## How to remove only $^3\text{He}$ from diluted $^4\text{He}$

- The mixing chamber connects to a distiller ('still'), which distills the  $^3\text{He}$  from the  $^4\text{He}$  due to the difference in vapour pressure
- Heat is applied to the still (otherwise it will quickly cool to a temperature where the vapour pressure is so low that the circulation stops)
- More power to the still means a higher circulation rate, which means more cooling power
- On the other hand, if the still temperature is too high, the vapour pressure of  $^4\text{He}$  will become significant. Circulating too much  $^4\text{He}$  will reduce the dilution process efficiency
- In practice, a  $^3\text{He}$  fraction of  $\sim 90\%$  in the circulated gas is acceptable, resulting in an optimal still temperature of 0.7 - 0.8 K. The approximate relationship between still temperature and  $^3\text{He}$  fraction is shown in the figure (right)

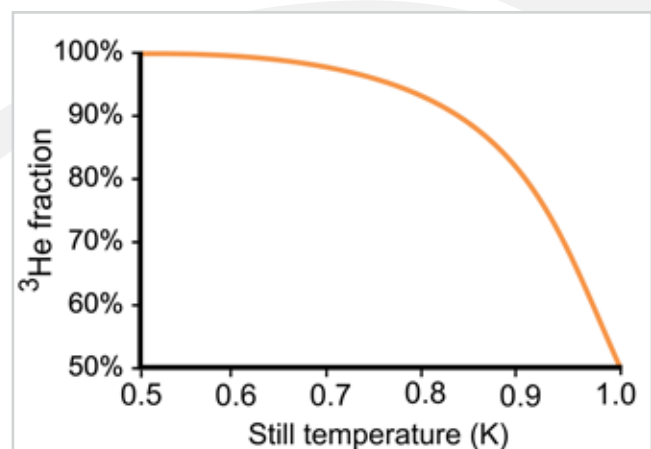
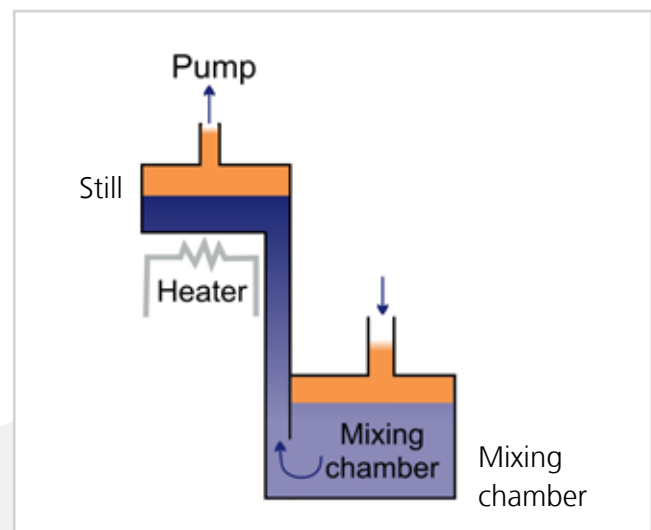

## The osmotic pressure

- As we pump  $^3\text{He}$  vapour from the liquid inside the still, the  $^3\text{He}$  concentration in the liquid will decrease
- The difference in  $^3\text{He}$  concentration between the still and the mixing chamber results in an osmotic pressure gradient along the connecting tube
- This osmotic pressure pulls  $^3\text{He}$  from the mixing chamber
- Note: Because  $^3\text{He}$  in  $^4\text{He}$  behaves as a Fermi gas, the osmotic pressure difference  $\Delta\pi$  can be understood from the ideal gas law (or more correctly Hoff's law), from which it follows that the maximum osmotic pressure is almost 20 mbar, equivalent to the hydrostatic pressure of 1 meter of liquid helium. This means the osmotic pressure difference is large enough to 'suck'  $^3\text{He}$  from the mixing chamber even if they are separated by a vertical difference of 1 meter

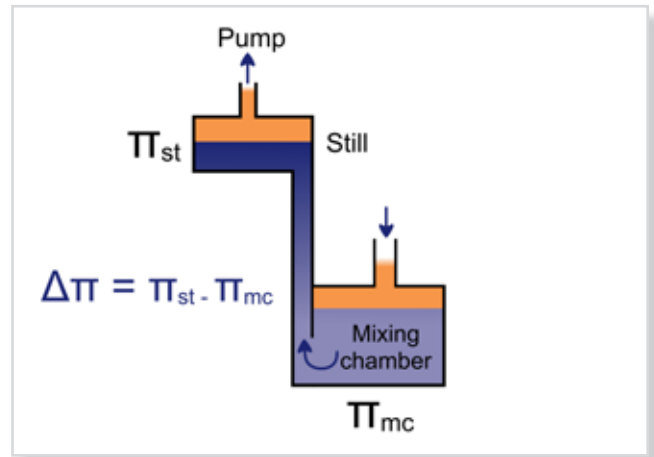

## Dilution refrigeration vs evaporative cooling

- The  $^4\text{He}$  component of a dilution refrigerator is effectively just a static background which is there to enable the  $^3\text{He}$  to transition from its pure liquid state and into a Fermi gas
- The 'dilution process' of  $^3\text{He}$  moving across the phase boundary is equivalent to an upside-down evaporator
- The importance of the finite solubility of  $^3\text{He}$  in  $^4\text{He}$  should now be clear. While the lowest achievable temperature in an evaporator is limited by exponentially decreasing vapour pressure, the equivalent to vapour pressure in a dilution refrigerator (the concentration of  $^3\text{He}$  in the Fermi gas) is constant with temperature
- The lowest achievable temperature is limited by the much weaker temperature dependence of the enthalpy of Fermi liquids ( $T^2$ )

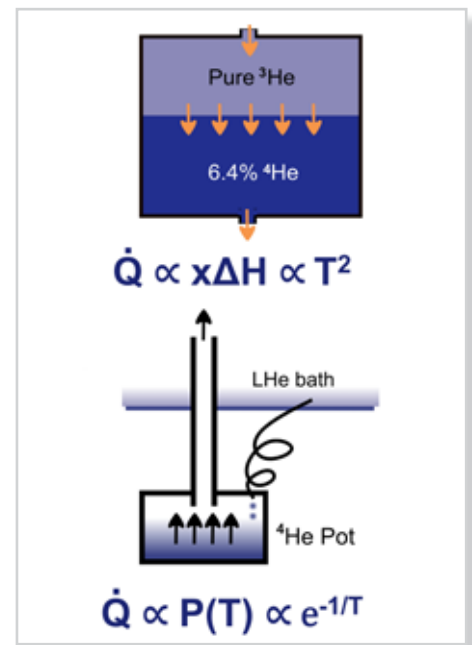

## 'Wet' dilution refrigerator

- A small amount of liquid helium from the main bath feeds the 1 K pot
- A dedicated pot pump keeps the 1 K pot cold
- An impedance ensures the condensing pressure is high enough ( $\sim 0.3$  bar) for the returning  $^3\text{He}$  to liquefy
- Several different types of heat exchanger precool the  $^3\text{He}$  before it reaches the mixing chamber
- Dilution cooling occurs in the mixing chamber
- The osmotic pressure drives the  $^3\text{He}$  up to the still where it is separated from the  $^4\text{He}$
- A room temperature gas handling system and pumps are used to recycle the  $^3\text{He}$  back into the return line

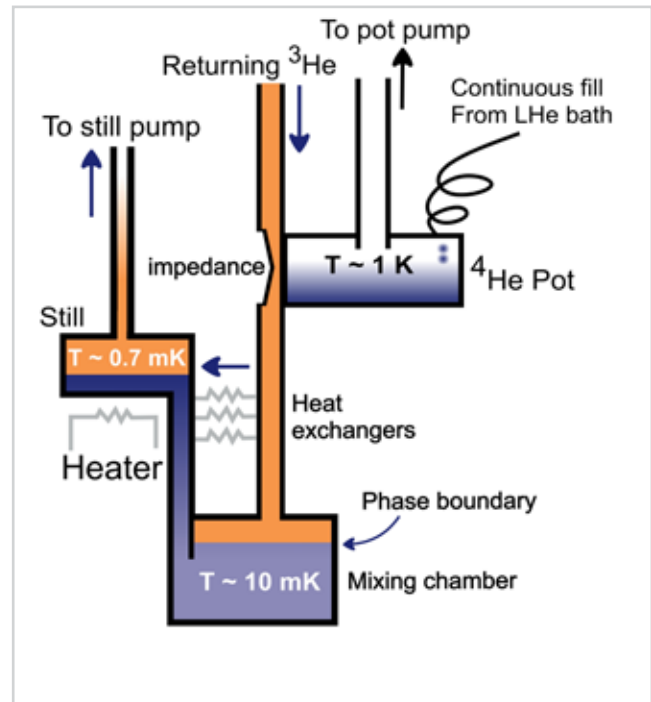

## 'Dry' dilution refrigerator

- The 1 K pot has been replaced by an extra heat exchanger located just before the impedance. The returning  $^3\text{He}$  is cooled by the outgoing  $^3\text{He}$  vapour from the still
- This heat exchanger in combination with the Joule-Thompson (JT) expansion happening in the impedance is enough to condense the gas
- The JT stage is not as efficient as a 1 K pot, so the condensing pressure is higher: typically 2.5 bar during the initial condensation, which drops to  $\sim 0.5$  bar near base temperature where the circulation rate is lower
- The higher condensing pressure means an additional high pressure pump (or compressor) is required when circulation is started. It can be switched off when the system has reached base temperature

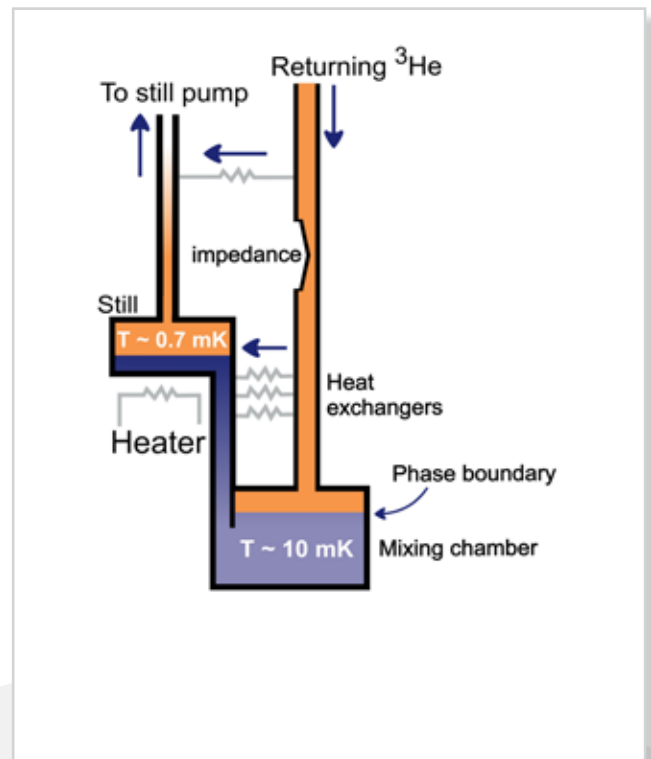

# Helium 3 circulation pumps



Either a turbo pump or a roots pump can be used at the low pressure end. Turbo pumps are oil-free, which means less risk of introducing contamination.

Either a rotary pump or a scroll pump can be used as a backing pump. Rotary pumps are cleaner (scroll pumps generate dust which may cause blockage or damage other pumps).

Either a diaphragm pump or a scroll pump can be used at the high-pressure end. A diaphragm pump is the cleanest option and it can generate a higher outlet pressure (4 bar as oppose to only 1.5 bar). This reduces the condensing time.

## The dilution unit

The dilution unit is the heart of the system. It has five main design criteria:

- Minimise the effect of thermal resistance between liquid helium and metals (Kapitza resistance). This enables efficient heat exchangers and therefore a lower base temperature
- Minimise the effect of viscous heating. This enables a high  $^3\text{He}$  circulation rate and therefore a higher cooling power
- Limit the superfluid film flow in the still. This ensures about 90% pure  $^3\text{He}$  is being circulated
- Minimise the amount of  $^3\text{He}$  required for operation reducing cost and preserving this rare and limited resource
- Remain leak tight for many years

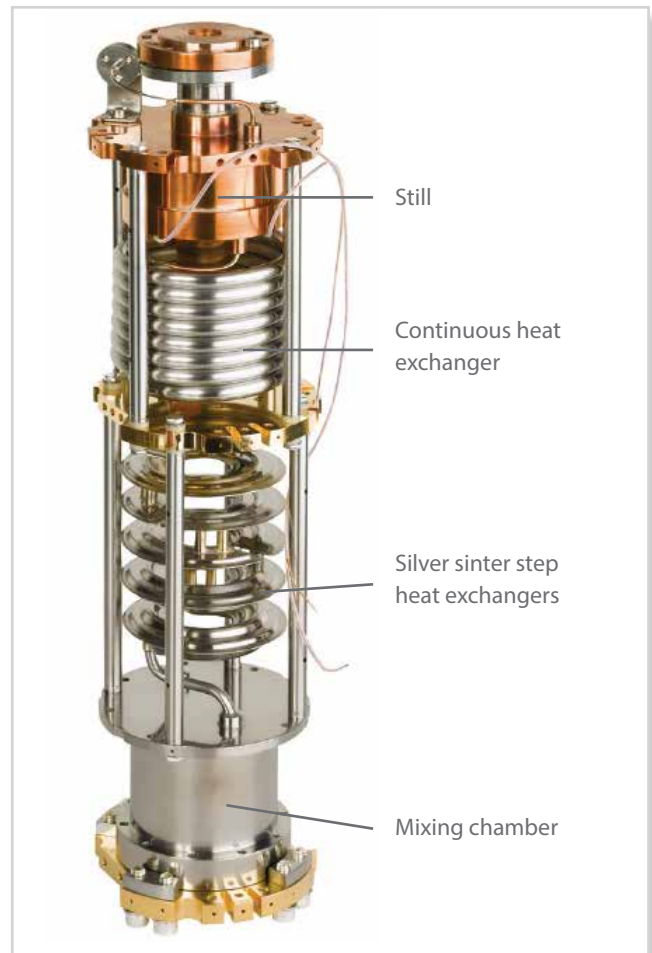

Dilution unit for operations below 10 mK





# Low temperature properties of helium

The main engineering challenges when building a refrigerator are due to the following thermal effects:

### Kapitza resistance

- The thermal resistance is inversely proportional to  $T^3$ , so as we approach  $T = 0$  K, designing heat exchangers become more of a challenge
- The solution is to increase the surface area by using sintered silver – typically  $1 \text{ m}^2/\text{g}$  of silver

### Viscous heating

- The viscosity of  $^3\text{He}$  increases with lower temperature and the viscosity of  $^3\text{He}$  in the diluted phase is 8 times higher than in the concentrated phase
- The friction associated with a viscous fluid flowing through a small channel results in heating, which must be minimised
- The solution is to increase the diameter of the flow channels
- The challenge of course is that larger flow channels conduct more heat and will also need more expensive  $^3\text{He}$

# Heat exchangers

- A continuous tube-in-tube heat exchanger is used at the high temperature end where Kapitza resistance and viscous heating only plays a limited role. It is  $^3\text{He}$  efficient and works well down to around 30 mK
- Several step heat exchangers with sintered silver are used at the low temperature end. The size of the flow channels and the amount of silver is increased in each step towards lower temperatures. Most of the  $^3\text{He}$  used in a dilution refrigerator is required for the step heat exchangers

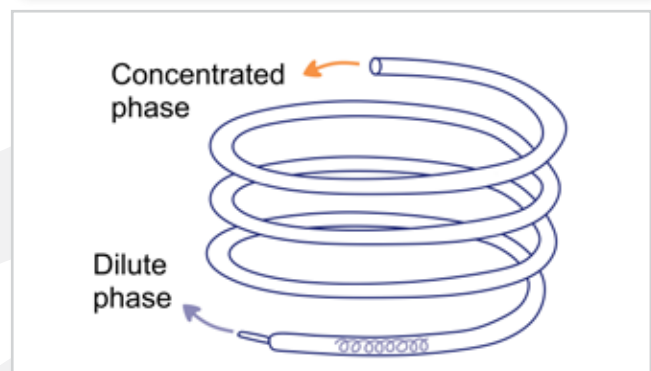
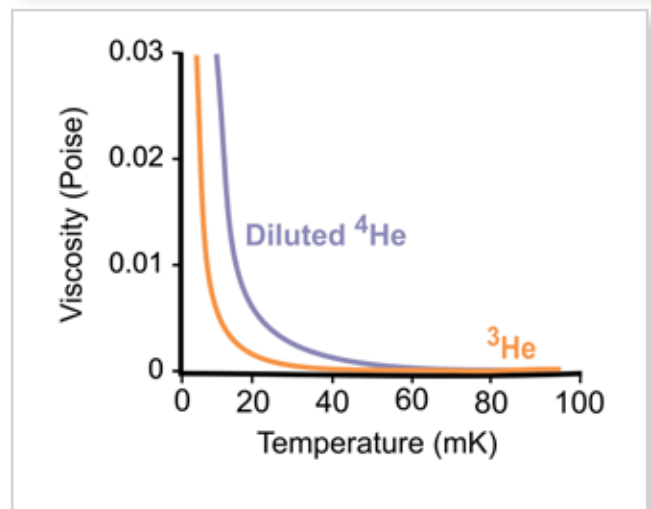
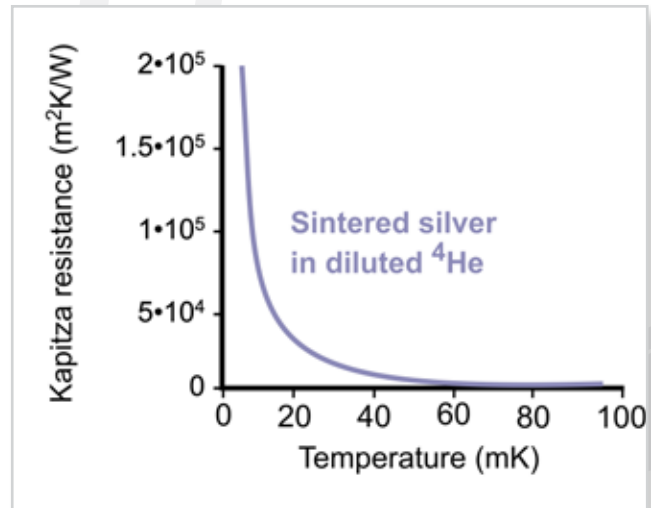

Coil heat exchanger (used at higher temperatures)

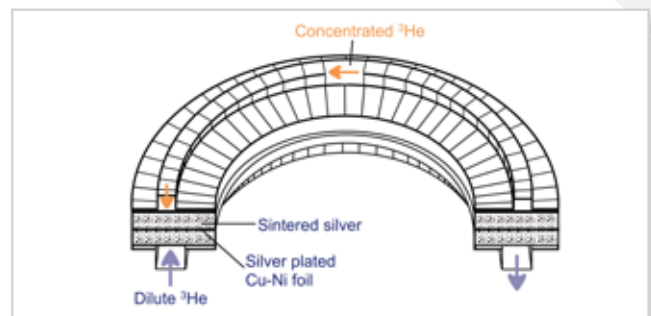

Sintered silver heat exchanger (used at the lowest temperature)

## The dilution refrigerator assembly

The photograph shows a typical 'dry' dilution refrigerator assembly. Typical experimental requirements to consider are:

- Vibrations from the pulse-tube cooler reduced to  $<100$  nm on the experimental plates
- Total system cool down time  $< 24$  h
- Gas handling and software for automatic operation
- Integration of semi-rigid coaxes, RF components, DC wiring looms and optical fibres
- Possibility to integrate a superconducting magnet
- Possibility to integrate a sample exchange mechanism to reduce the sample turnaround time

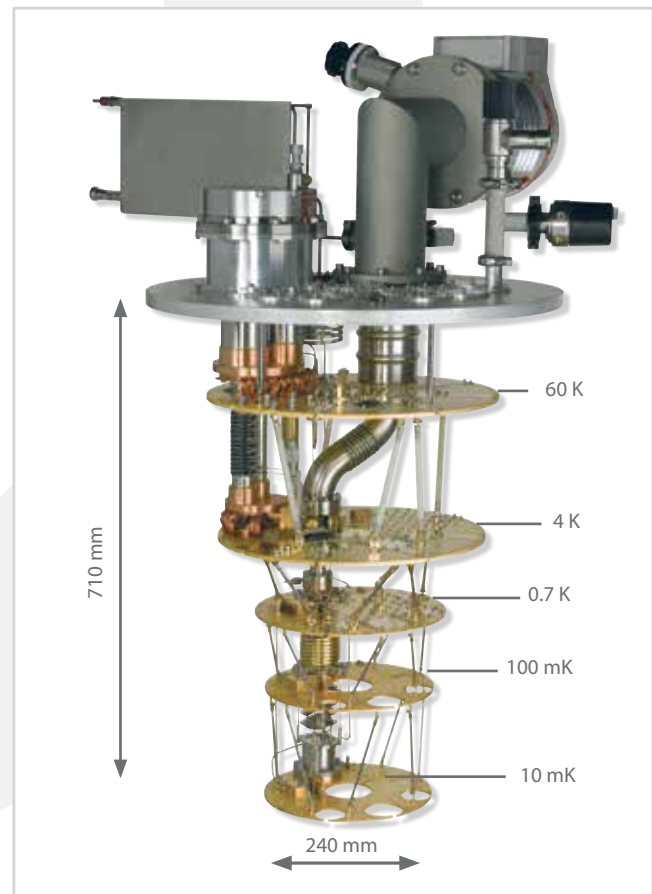

Internal assembly of a Cryofree dilution refrigerator

## Reducing vibrations

- Pulse tube technology enables relatively low vibrations (in comparison with other cryocoolers): typically 5-10 micron on the cold head stages
- Most experiments require sub-micron vibrations in order to eliminate microphonic noise from the experimental wiring
- The best approach to tackle this problem is to use copper braids to decouple the pulse tube stages from the experimental plates
- Using a combination of braids and a very stiff support structure it is possible to achieve  $< 100$  nm vibrations

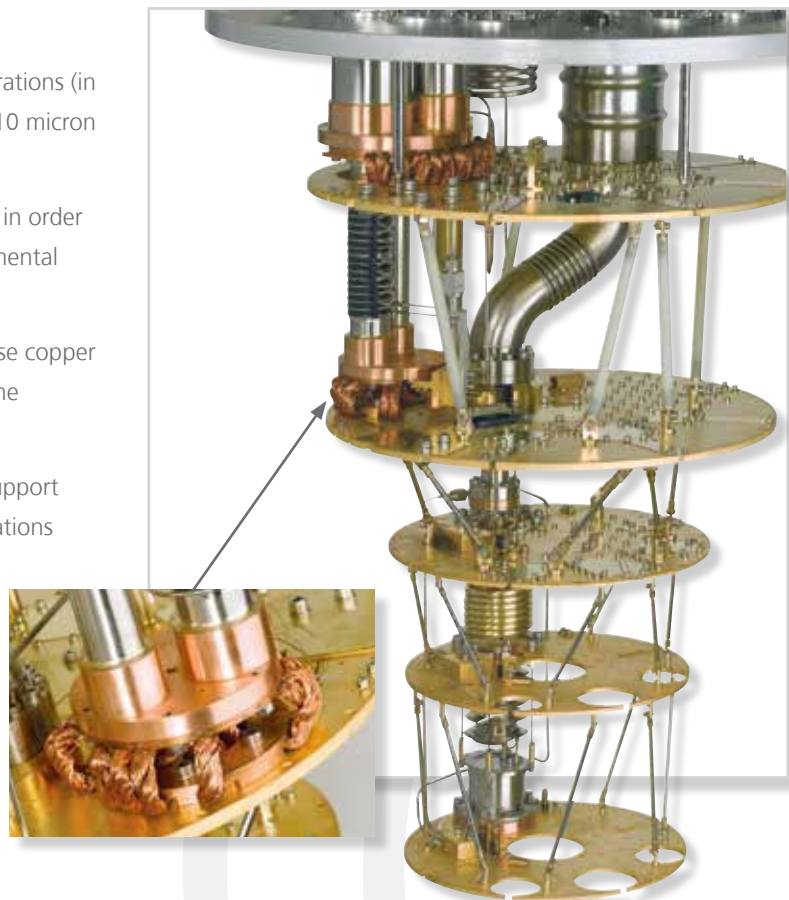

## Pre-cooling mechanism

- The dilution unit with its three experimental plates need to be cooled from 300 K to ~10 K before mixture condensation can commence
- Wet systems usually enclose the cold stages with an inner vacuum chamber (IVC) which is filled by exchange gas, which is later evacuated
- The pre-cool line (shown in red) removes the need for an IVC. Instead a small amount of mixture is circulated through the pre-cool loop using the membrane pump
- A pre-cool line makes the sample exchange much easier and faster with no need to use indium seals (as on a wet system) and thus reducing risk for developing cold leaks
- Circulating mixture through the low impedance pre-cool line also allows for good temperature control at higher
- Cool down time is reduced by removing the need for the thermal mass of an IVC

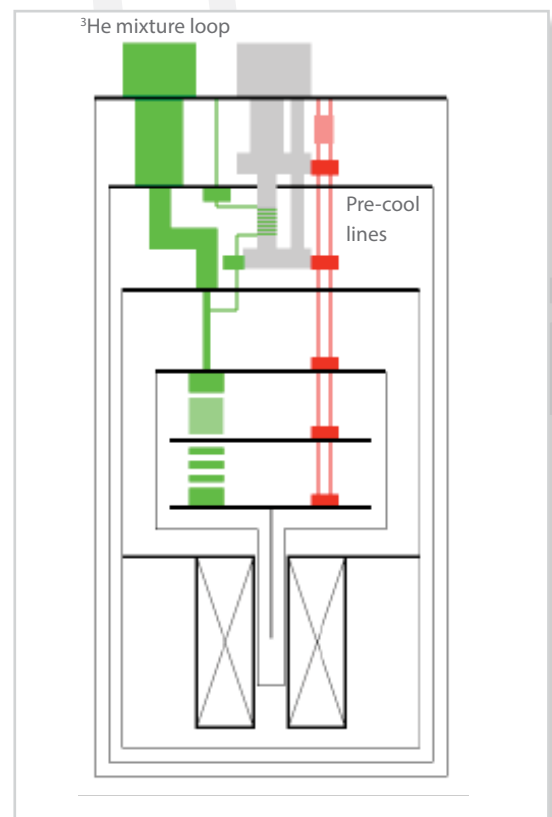

## Gas handling and software

Dilution refrigerators need a gas handling system which can automate their operation. Typical requirements to consider are:

- Software for monitoring and logging pressure readings, temperatures and any error messages
- Automatic procedures for cooling and warming the system, condensing and collecting the mixture
- Automatic safety interlocks and pressure-relief valves to protect the system in case of operator error or extended power cuts
- Possible integration of a UPS to allow the software to restore the system in case of a power cut
- A command interface to enable remote system control with, for example, LabVIEW and easy integration with other control languages such as Python, Matlab, C++ and many more



## Integrated superconducting magnets

- In order to avoid eddy current heating effects from vibrations in magnetic fields, the superconducting magnet should be cooled by the same pulse tube cooler as that of the dilution refrigerator
- Mounting the magnet and the dilution refrigerator on the same 4 K stage as shown in the photo on the right ensures that any motion will be common to both
- Integrated cryogen free solenoid magnets up to 18 T, split pair magnets with optical access and a variety of vector magnets to tilt or rotate the field with respect to the sample are now commercially available

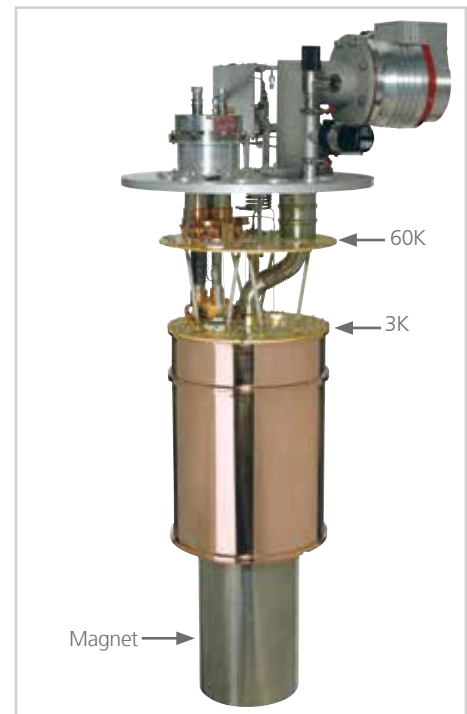

## Sample exchange mechanism

- Large magnets add significantly to the overall system cool down time. A system with an integrated 14 T solenoid typically takes 45 hours to reach base temperature unaided
- A top or bottom loading mechanism allows a new sample to be cooled overnight and also greatly simplifies the manual work involved
- The figure shows the principle of a bottom loading mechanism where a demountable 'puck' loads through a series of baffles and attaches to the mixing chamber plate with a bolted contact
- The sample puck in the photograph has provision for up to 14 RF connections plus 50 DC connections
- The wires connecting the sample to room temperature are permanently installed on the fridge platform (and remain cold when changing the sample). This reduces the heat load to the sample and therefore offers best performance
- Some designs use a wiring 'stick' with clamps creating thermal contacts to higher temperature stages
- The sample puck method has two significant advantages over the sample stick concept: firstly, having the wiring on the fridge platform means there is much more space available for installing filters or additional RF components. Secondly, because the heat load from wires is dissipated directly on the fridge instead of on the sample holder, the achievable sample temperature will always be lower with a demountable puck than with a wiring stick. The demountable puck is currently the only method able to achieve <10 mK sample temperatures

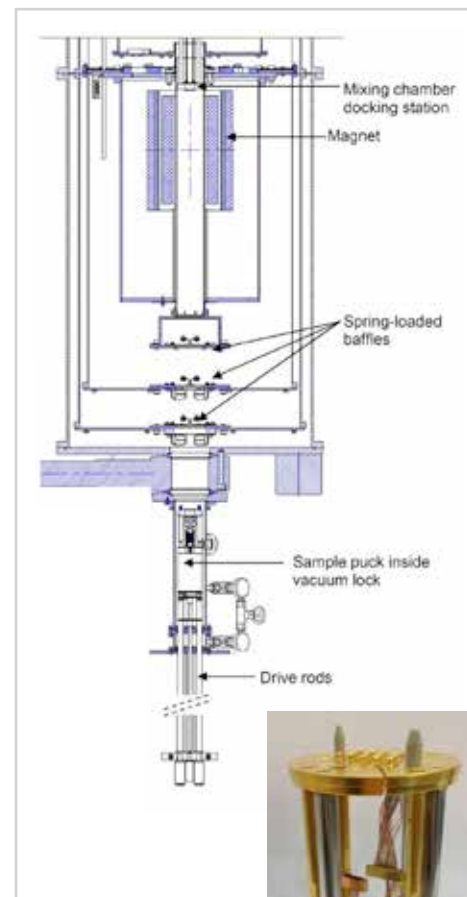



## Dilution refrigerators at the leading edge of physics

Dilution refrigerators have been used for a large number of significant scientific advancements in, for example, graphene, topological insulators, quantum dots and superconducting circuits, and quantum computing/quantum information processing (QIP).

Two Nobel Prizes for Physics have been based on experiments using dilution refrigeration.

Superfluidity in  $^3\text{He}$  was discovered in 1971 by Lee, Osheroff and Richardson using a dilution refrigerator, equipped with a Pomeranchuk cooling stage. Their results laid the groundwork for the study of quantum materials that display macroscopic quantum effects. They were awarded the Nobel Prize for Physics in 1996.

The discovery of the fractional quantum Hall effect in 1981 by Daniel Tsui, Horst Störmer and Robert Laughlin was done using a top loading into mixture (TLM) dilution refrigerator. This work, which was awarded the Nobel Prize for Physics in 1998, led to a breakthrough in our understanding of quantum physics and to the development of new theoretical concepts of significance in many branches of modern physics.

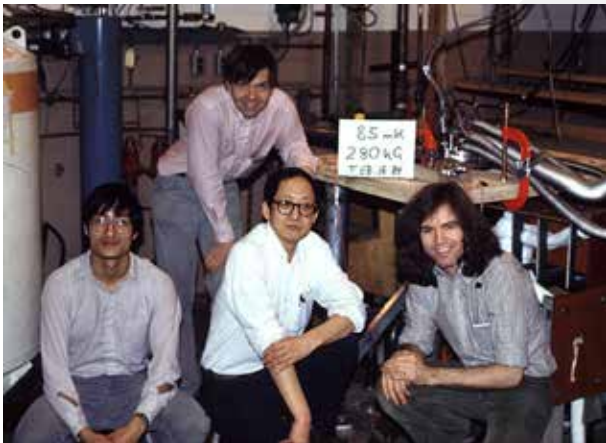

Albert Cheng, Peter Berglund, Daniel Tsui and Horst Störmer (from the left)



Robert C. Richardson - © Cornell University photography

## Further reading:

The following reference articles and publications contain useful background information about the fundamentals of cryogenics and low temperature systems.

Integration of superconducting magnets with cryogen free dilution refrigerator systems

(doi: 10.1016/j.cryogenics.2009.09.008)

[Download the article here](#)

A micro Kelvin Cryofree platform with noise thermometry

(doi: 10.1088/1367-2630/15/11/113034)

[Download the article here](#)

A rapid sample-exchange mechanism for cryogen free dilution refrigerators compatible with multiple high frequency signal connections

(doi: 10.1016/j.cryogenics.2014.01.007)

[Download the article here](#)

A new ultra low temperature cryogen free experimental platform

(doi: 10.1088/1742-6596/568/3/032014)

[Download the article here](#)

History and Origins of Cryogenics: by Ralph G. Scurlock, Oxford University Press

Helium Cryogenics (2nd edition): by Steven W. Van Sciver, Springer Press, 2012, ISBN 978-1-4419-9979-5

Matter and Methods at Low Temperatures (3rd edition): by Frank Pobell, Springer-Verlag Berlin Heidelberg 2007, ISBN 978-3-540-46360-3

An Introduction to Milli-Kelvin Technology: by David S Betts, Cambridge University Press, 1989, ISBN 0-521-34456-5

Experimental Techniques in Condensed Matter Physics at Low Temperatures: by Robert C Richardson and Eric N Smith, Addison Wesley Publishing Company Inc, 1988, ISBN 0-201-15002-6

Experimental Techniques in Low Temperature Physics (3rd edition): by G K White, Oxford University Press, 1987, ISBN 0-19-851381-X (Pbk), ISBN 0-19-851359-3

Experimental Principles and Methods below 1 K: by O V Lounasmaa, Academic Press, 1974, ISBN 0-12-455950-6



# Oxford Instruments NanoScience

Oxford Instruments NanoScience designs, supplies and supports market-leading research tools that enable quantum technologies, new materials and device development in the physical sciences. Our tools support research down to the atomic scale through creation of high performance, cryogen free, low temperature and magnetic environments, based upon our core technologies in low and ultra low temperatures, high magnetic fields and system integration, with ever-increasing levels of experimental and measurement readiness.

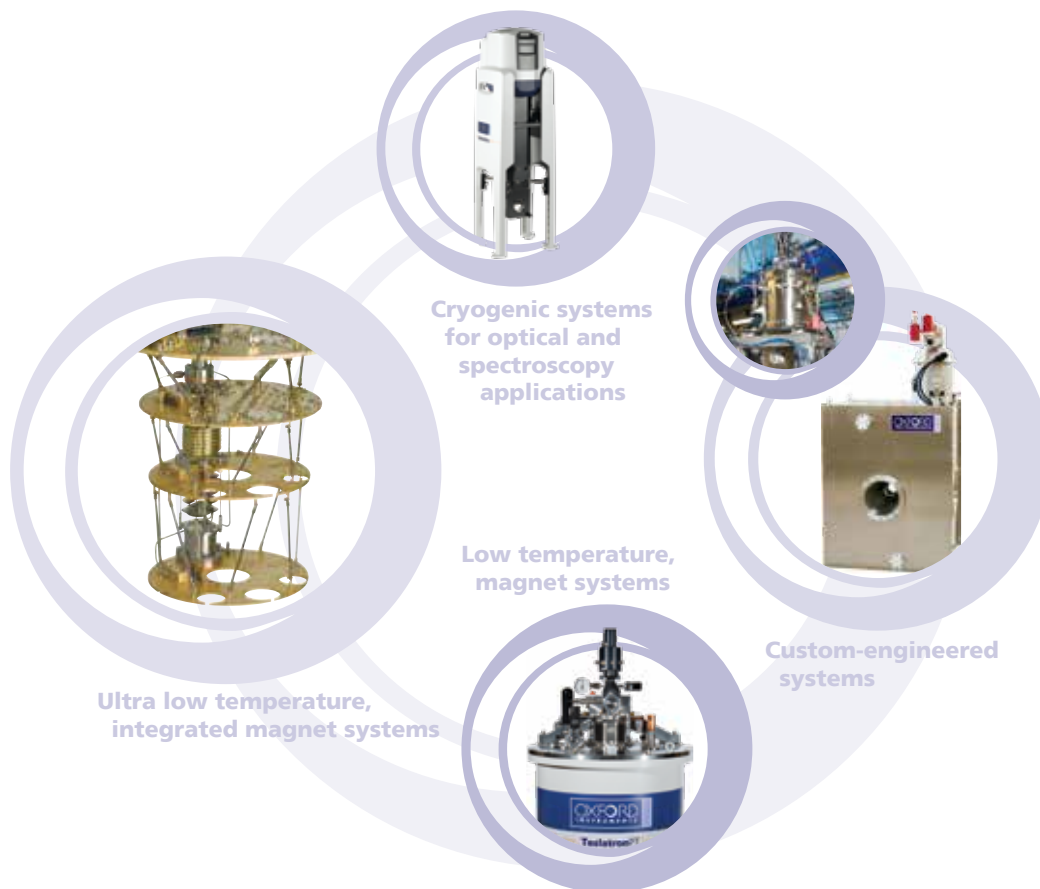

Please visit [www.oxford-instruments.com/nanoscience](http://www.oxford-instruments.com/nanoscience)

This publication is the copyright of Oxford Instruments plc and provides outline information only, which (unless agreed by the company in writing) may not be used, applied or reproduced for any purpose or form part of any order or contract or regarded as the representation relating to the products or services concerned. Oxford Instruments' policy is one of continued improvement. The company reserves the right to alter, without notice the specification, design or conditions of supply of any product or service. Oxford Instruments acknowledges all trademarks and registrations. © Oxford Instruments NanoTechnology Tools Ltd., 2015. All rights reserved.



*The Business of Science®*

