



AGH University of Science and Technology

Industrial Robots



**Laboratory no. 1**  
**ON-OFF POSITIONED**  
**DRIVING SYSTEMS OF MANIPULATORS**

# On-off positioned pneumatic manipulators – the use of cyclogram – basic (combinatory control) systems

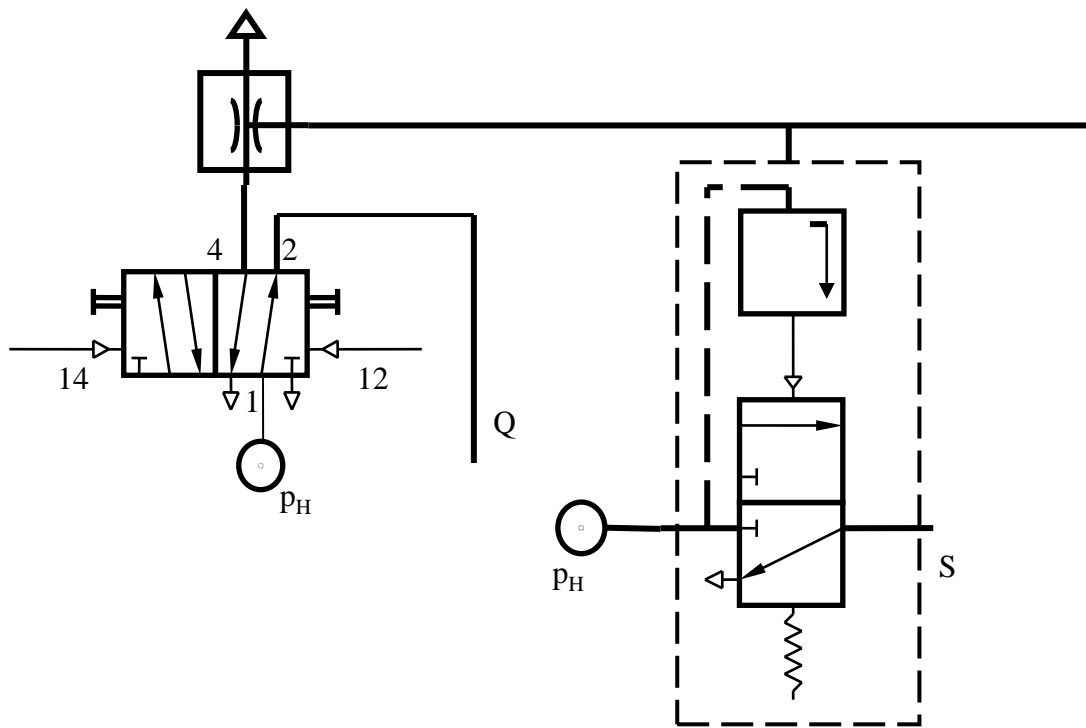

Linear motion module with a vacuum gripper

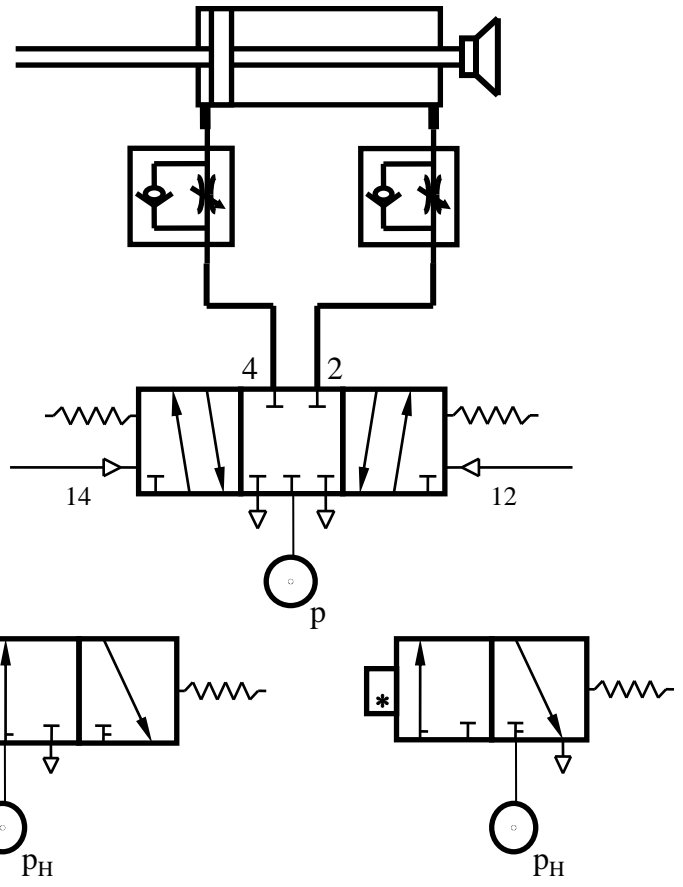

# A cyclogram

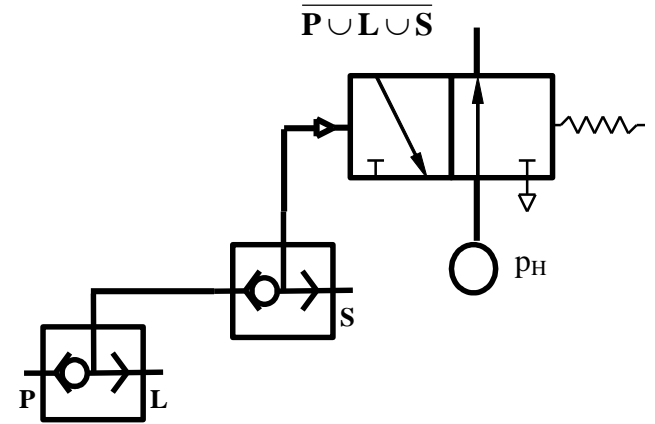
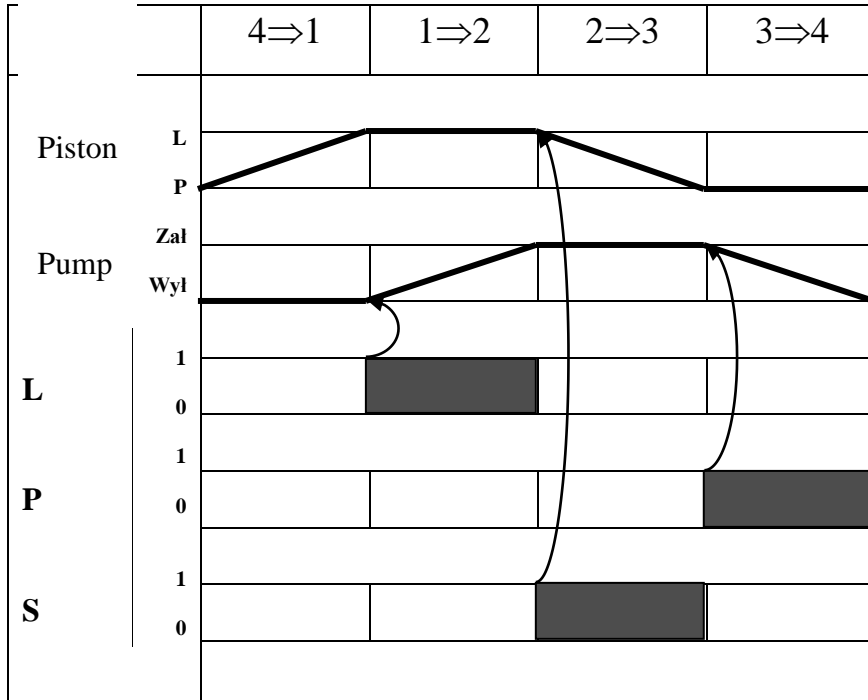

# A diagram of a linear motion unit with suction cup

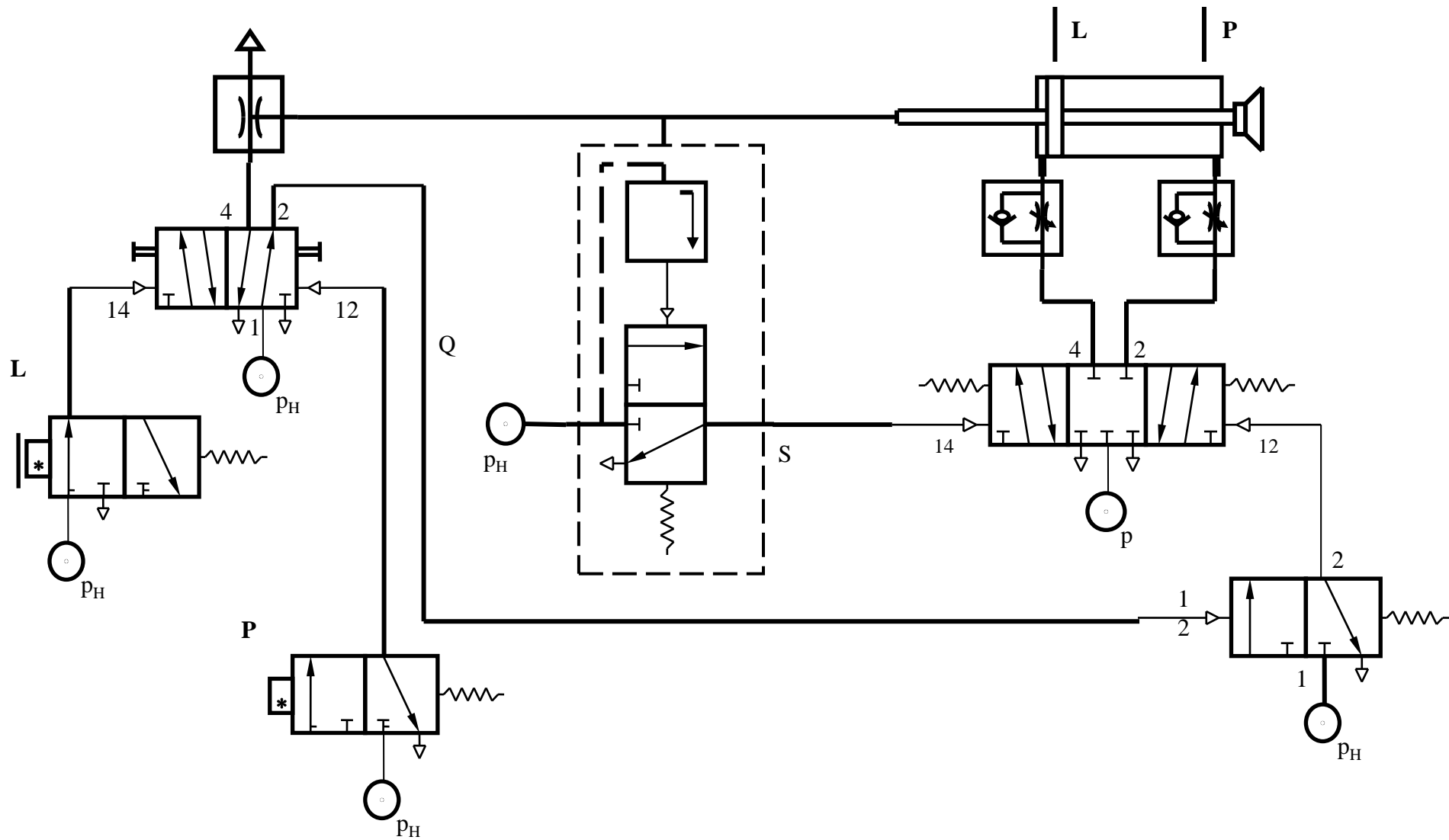

A task to be completed during classes:

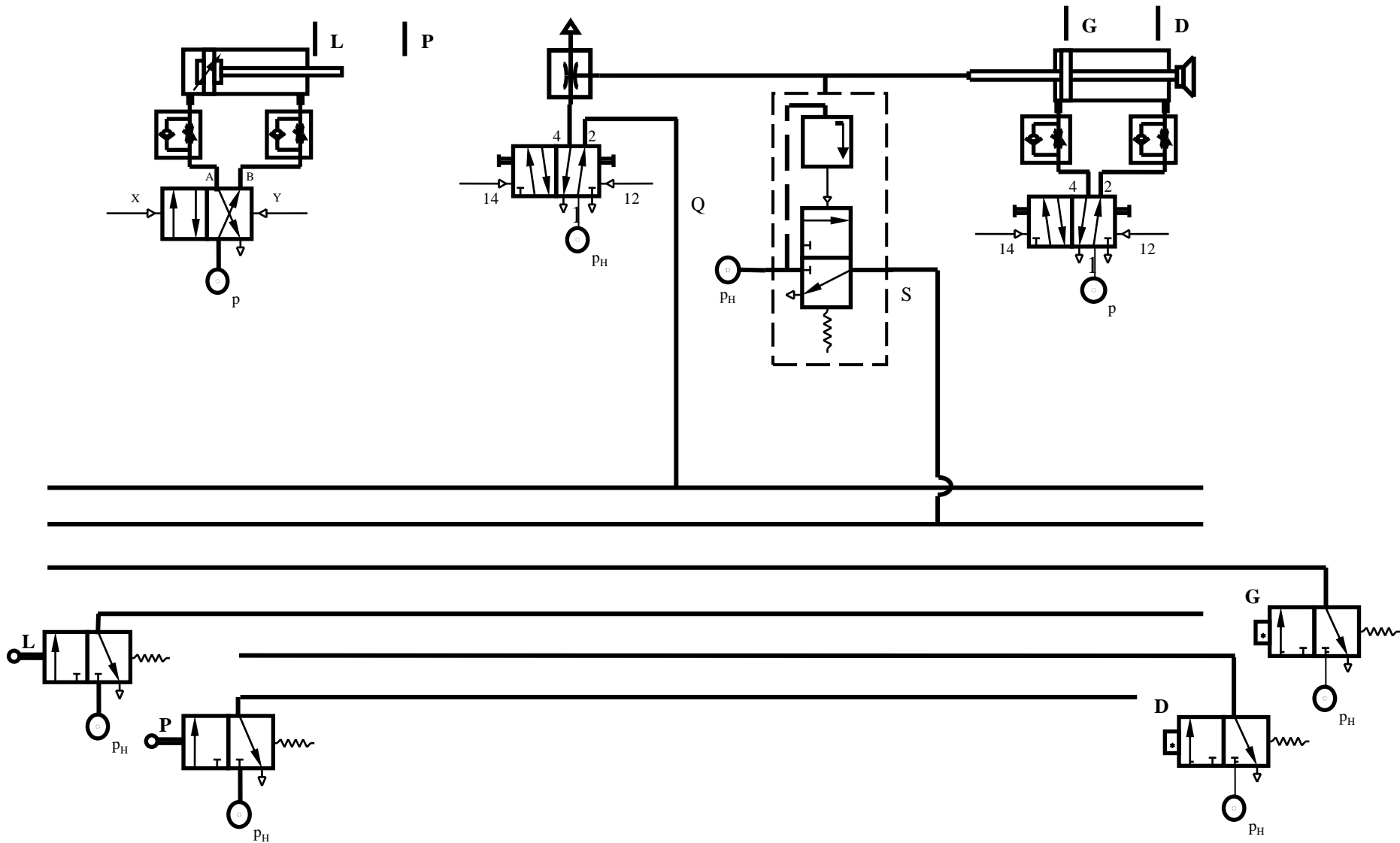

# Automation Studio – Vacuum pump and suction cup (Actuators / Vacuum Cylinders).

