

Exercise 2
Electronic Scale
Laboratory Instruction

prepared by:
Łukasz Śliwczyński
v2.1
04.2018
u. 04.2023

1. Aim of the exercise

The aim of the exercise is to get familiar with the operation of an electronic scale; measurement of the transfer characteristics of a tensometric transducer (also known as a load cell) operating in the bridge configuration; the use of unbalanced bridge and basic differential amplifiers. Developing skills in elaborating the measurement results, especially the uncertainty analysis in indirect measurements.

2. Circuit description

The schematic diagram of the model of the electronic scale used during the exercise is shown in Fig. 1; the localization of important components, test points, jumpers and connectors is shown in Fig. 2. The model includes an electronic scale, composed of the tensometric transducer (the load cell in the Roberval configuration), the instrumentation amplifier and necessary voltage shifter. The circuit may be supplied using either on-board +5 V voltage regulator or using external power supply (**cannot exceed +12 V**).

WARNING!!!

LOADING THE PLATE OF THE SCALE WITH EXCESSIVE LOAD MAY DESTROY THE LOAD CELL. PLEASE RESPECT THE MAXIMUM LOAD VALUE OF 500 g.

3. Preparation to the exercise

Items marked with (*) are obligatory, others are optional.

1. Read carefully the entire laboratory manual. (*)
2. From the lecture learn about the operation of the tensometer and the tensometric bridge in the Roberval configuration. Know how to explain the operation of the tensometric bridge and the influence of the temperature on the operation of the bridge. Learn the parameters of a typical load cell (sensitivity, maximum load, offset). (*)
3. Recognize the role of each functional block shown in the circuit diagram of the electronic scale (Fig. 1), i.e. the load cell and amplifier block, the reference voltage block and the power supply block. (*)
4. Draw the block diagram of the electronic scale using the blocks shown in Fig. 1, i.e. the load cell and amplifier block, the reference voltage block and the power supply block. When drawing entire diagram use the designation of the test points (e.g. TP1, TP2 etc.) and jumpers (e.g. JP1, JP2 etc.), which are used in Fig. 1. Note – this should be a block diagram, showing only the most important connections. (*)
5. Mark the connections between the load cell and the rest of the circuit. (*)
6. Draw the internal connections between the individual tensometers inside the load cell, marking the terminals for measuring the resistances (where one can connect an ohmmeter), the power supply terminals and the terminals for the measurement of the offset voltage (the voltage across the bridge when the plate is not loaded). The drawing should be large enough to allow you to note on it the results of the measurements of the corresponding values when making the exercise (you can use the diagram shown in the Appendix as a suggestion). (*)

7. From the manual of the multimeter (Agilent U3401A / Rigol DM3068, available from the course webpage) read and copy to your notebook the uncertainty of the measurements of the resistance and the DC voltage. You should understand the meaning of these parameters and know how to explain them. (*)
8. Write the equation allowing a determination the offset voltage of the load cell using the measured resistances and the supply voltage (you may follow some suggestions given in the Appendix at the end of this instruction). (*)
9. Derive and write the equation allowing you to calculate the combined uncertainty and expanded uncertainty using as a result of indirect measurement of resistances and supply voltage. Prepare the table for calculating the uncertainty budget basing on the examples presented during the lecture.
10. Write the equations for the sensitivity of the scale (in units [mV/kg] or [V/kg]) of the circuit in the configuration with and without the instrumentation amplifier.

4. Exercise plan

1. Disconnect the bridge from the circuit removing appropriate jumpers. Measure the resistances of the bridge using the ohmmeter. Write the results on prepared diagram of the bridge (point 6 of the preparation part). Make sure that there are no weights on the scale during this measurement.
2. Using the voltmeter measure the voltage supplying the bridge (jumper controlling the power supply set in position A, power supply of the bridge on; **the power supplying the circuit can not exceed +12 V**) and the offset voltage of the bridge.
3. Measure the transfer characteristics of the load cell using the voltmeter (you should set it to allow the reading with the mV resolution) by placing a set of reference weights on the scale, without amplifier connected. Repeat the measurement in reversed direction (i.e. removing the weights from the plate). Number of weights and the weights of particular weights choose accordingly to the maximum load of the load cell.
4. Connect appropriate jumpers to perform the measurement of the transfer characteristics of the load cell with the amplifier.
5. Check whether the reading of the scale depends on the place where the loading weight is put on its plate (use three reasonably chosen points), describe this in your notebooks.
6. Repeat the measurement of the transfer characteristic of the circuit (the load cell + differential amplifier) increasing the supply voltage (jumper selecting the power supply changed from position A into position B). Measure this voltage and write it in your notebook.

5. Data processing

For the data processing purposes it is of particular importance to write down the data in the correct format including its uncertainties. **Items marked with (*) are obligatory, others are optional.**

- i. Using the results of point 4.1 (resistances) and 4.2 (voltage supplying the load cell) and using appropriate equations (worked out during the preparation to the exercise) calculate the offset voltage. (*)
- ii. Calculate the combined uncertainty of the offset voltage - you may present it in the form of the uncertainty budget. (*)
- iii. Compare the calculated and measured offset voltages; discuss the result of this comparison. Are the results consistent? Do they agree within estimated uncertainties? (*)
- iv. Plot the transfer characteristics using the data measured in point 4.3, determine the sensitivity of the transducer (in units of [mV/kg]). Comment whether the sensitivity depends on the actual loading of the plate. Check possible hysteresis of the transducer. (*)
- v. Determine the offset voltage and the sensitivity using the data measured in point 4.
- vi. Comment the operation of the circuit depending on the position of the weight on the plate.
- vii. Determine the gain of the differential amplifier using the data from the points 4.3 and 4.4. Calculate the uncertainty of determined gain. Comment whether the gain depends on actual loading of the plate. What may be the reason of the change of the gain? (*)
- viii. Determine the sensitivity of the circuit with increased power supply value. What conclusions may you draw basing on this experiment?

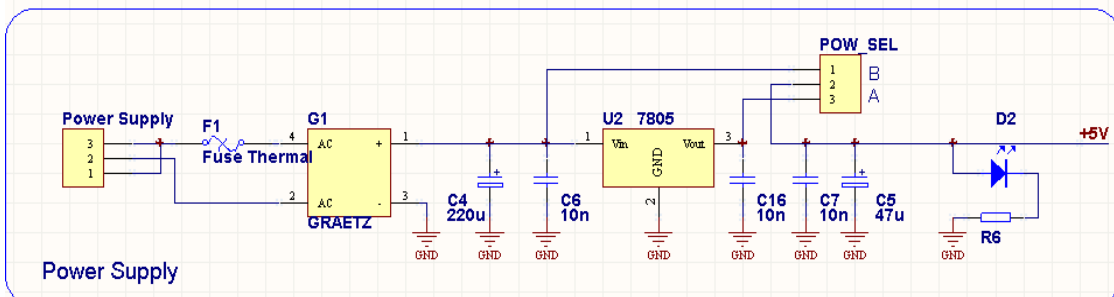
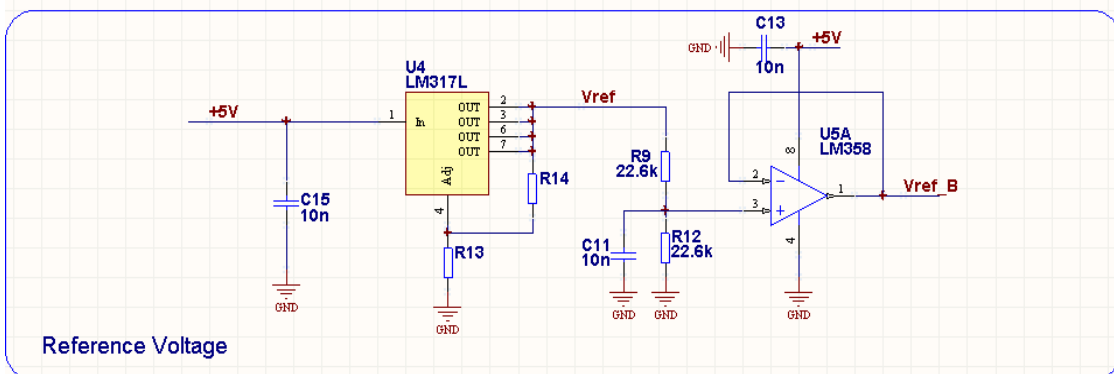
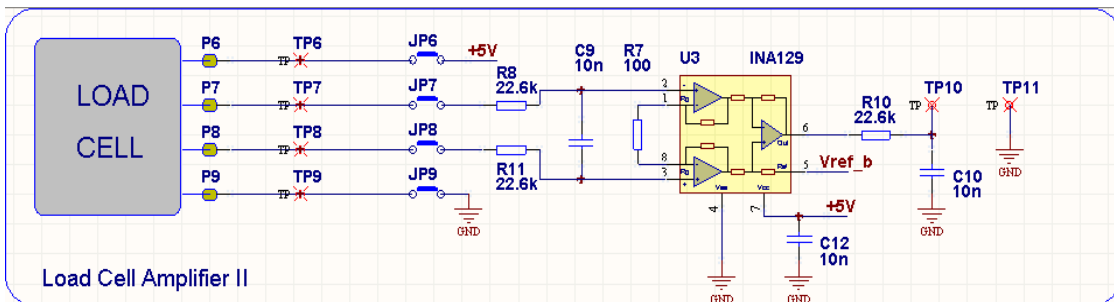

Fig. 1. Schematic diagram of the laboratory electronic scale.

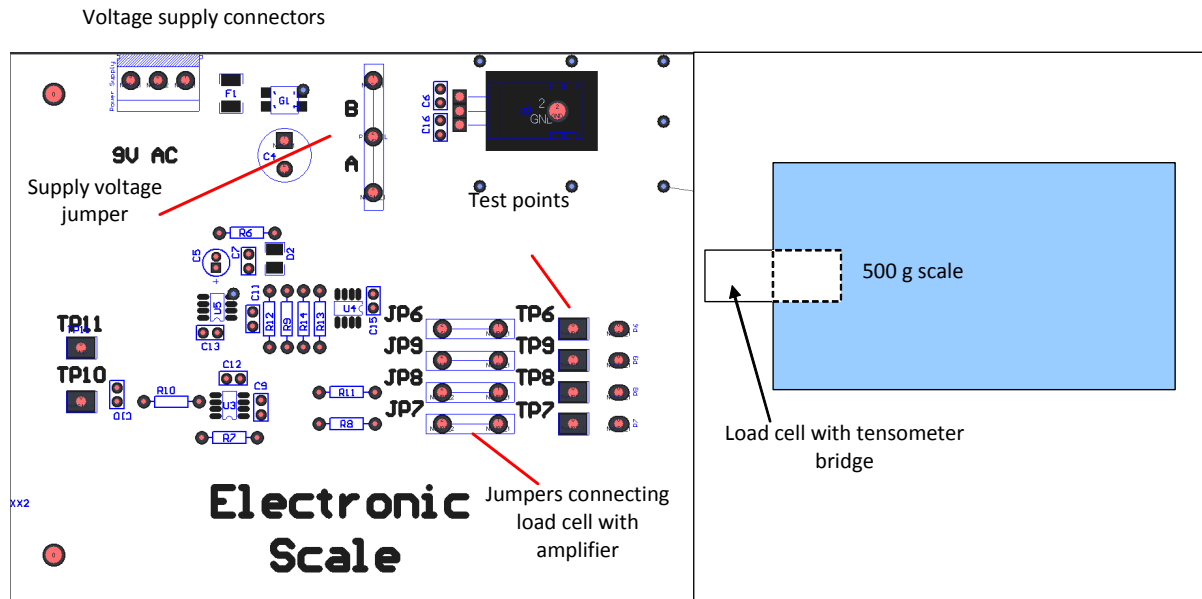
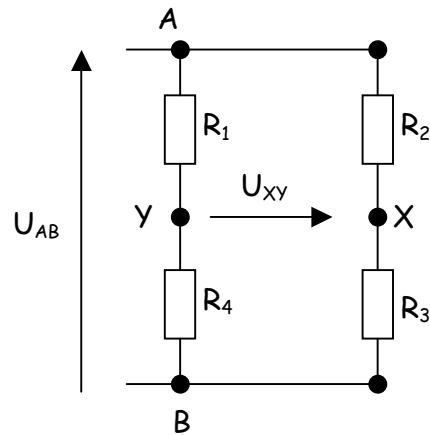

Fig. 2. Localization of test points (TP, J) and jumpers (JP).

Appendix

Determining the offset voltage using the resistances of the tensometric bridge.



The voltage U_{XY} may be determined the formula for the voltage divider applying for the two times:

$$U_{XY} = U_{XB} - U_{YB} = U_{AB} \cdot X, \text{ where } X = \frac{R_2 R_4 - R_1 R_3}{(R_1 + R_4)(R_2 + R_3)}.$$

The formula for X may be written as a function of five resistances of the bridge circuits:

$$R_{AY} = \frac{R_1(R_2 + R_3 + R_4)}{R_1 + R_2 + R_3 + R_4}$$

$$R_{AX} = \frac{R_2(R_1 + R_3 + R_4)}{R_1 + R_2 + R_3 + R_4}$$

$$R_{BX} = \frac{R_3(R_1 + R_2 + R_4)}{R_1 + R_2 + R_3 + R_4}$$

$$R_{BY} = \frac{R_4(R_1 + R_2 + R_3)}{R_1 + R_2 + R_3 + R_4}$$

$$R_{AB} = \frac{(R_1 + R_4)(R_2 + R_3)}{R_1 + R_2 + R_3 + R_4}$$

Observing the forms of the above formulas it should be quite obvious how to derive the equation for U_{XY} as a function of measurable quantities R_{AY} , ..., R_{BY} i R_{AB} .