

IEEE Standard for Synchrophasor Measurements for Power Systems

IEEE Power & Energy Society

Sponsored by the
Power System Relaying Committee

IEEE
3 Park Avenue
New York, NY 10016-5997
USA

IEEE Std C37.118.1™-2011
(Revision of
IEEE Std C37.118™-2005)

28 December 2011

IEEE Std C37.118.1™-2011

(Revision of
IEEE Std C37.118™-2005)

IEEE Standard for Synchrophasor Measurements for Power Systems

Sponsor

Power System Relaying Committee
of the
IEEE Power & Energy Society

Approved 7 December 2011

IEEE-SA Standards Board

Abstract: Synchronized phasor (synchrophasor) measurements for power systems are presented. This standard defines synchrophasors, frequency, and rate of change of frequency (ROCOF) measurement under all operating conditions. It specifies methods for evaluating these measurements and requirements for compliance with the standard under both steady-state and dynamic conditions. Time tag and synchronization requirements are included. Performance requirements are confirmed with a reference model, provided in detail. This document defines a *phasor measurement unit* (PMU), which can be a stand-alone physical unit or a functional unit within another physical unit. This standard does not specify hardware, software, or a method for computing phasors, frequency, or ROCOF.

Keywords: data concentrator, DC, FE, frequency error, IEEE C37.118.1, IRIG-B, PDC, phasor, phasor measurement, phasor measurement unit, PMU, RFE, ROCOF, ROCOF error, synchronized phasor, synchrophasor, total vector error, TVE

The Institute of Electrical and Electronics Engineers, Inc.
3 Park Avenue, New York, NY 10016-5997, USA

Copyright © 2011 by the Institute of Electrical and Electronics Engineers, Inc.
All rights reserved. Published 28 December 2011. Printed in the United States of America.

IEEE is a registered trademark in the U.S. Patent & Trademark Office, owned by the Institute of Electrical and Electronics Engineers, Incorporated.

PDF: ISBN 978-0-7381-6811-1 STD97167
Print: ISBN 978-0-7381-6812-8 STDPD97167

IEEE prohibits discrimination, harassment and bullying. For more information, visit <http://www.ieee.org/web/aboutus/whatis/policies/p9-26.html>. No part of this publication may be reproduced in any form, in an electronic retrieval system or otherwise, without the prior written permission of the publisher.

IEEE Standards documents are developed within the IEEE Societies and the Standards Coordinating Committees of the IEEE Standards Association (IEEE-SA) Standards Board. The IEEE develops its standards through a consensus development process, approved by the American National Standards Institute, which brings together volunteers representing varied viewpoints and interests to achieve the final product. Volunteers are not necessarily members of the Institute and serve without compensation. While the IEEE administers the process and establishes rules to promote fairness in the consensus development process, the IEEE does not independently evaluate, test, or verify the accuracy of any of the information or the soundness of any judgments contained in its standards.

Use of an IEEE Standard is wholly voluntary. The IEEE disclaims liability for any personal injury, property or other damage, of any nature whatsoever, whether special, indirect, consequential, or compensatory, directly or indirectly resulting from the publication, use of, or reliance upon this, or any other IEEE Standard document.

The IEEE does not warrant or represent the accuracy or content of the material contained herein, and expressly disclaims any express or implied warranty, including any implied warranty of merchantability or fitness for a specific purpose, or that the use of the material contained herein is free from patent infringement. IEEE Standards documents are supplied “**AS IS.**”

The existence of an IEEE Standard does not imply that there are no other ways to produce, test, measure, purchase, market, or provide other goods and services related to the scope of the IEEE Standard. Furthermore, the viewpoint expressed at the time a standard is approved and issued is subject to change brought about through developments in the state of the art and comments received from users of the standard. Every IEEE Standard is subjected to review at least every five years for revision or reaffirmation, or every ten years for stabilization. When a document is more than five years old and has not been reaffirmed, or more than ten years old and has not been stabilized, it is reasonable to conclude that its contents, although still of some value, do not wholly reflect the present state of the art. Users are cautioned to check to determine that they have the latest edition of any IEEE Standard.

In publishing and making this document available, the IEEE is not suggesting or rendering professional or other services for, or on behalf of, any person or entity. Nor is the IEEE undertaking to perform any duty owed by any other person or entity to another. Any person utilizing this, and any other IEEE Standards document, should rely upon his or her independent judgment in the exercise of reasonable care in any given circumstances or, as appropriate, seek the advice of a competent professional in determining the appropriateness of a given IEEE standard.

Interpretations: Occasionally questions may arise regarding the meaning of portions of standards as they relate to specific applications. When the need for interpretations is brought to the attention of IEEE, the Institute will initiate action to prepare appropriate responses. Since IEEE Standards represent a consensus of concerned interests, it is important to ensure that any interpretation has also received the concurrence of a balance of interests. For this reason, IEEE and the members of its societies and Standards Coordinating Committees are not able to provide an instant response to interpretation requests except in those cases where the matter has previously received formal consideration. A statement, written or oral, that is not processed in accordance with the IEEE-SA Standards Board Operations Manual shall not be considered the official position of IEEE or any of its committees and shall not be considered to be, nor be relied upon as, a formal interpretation of the IEEE. At lectures, symposia, seminars, or educational courses, an individual presenting information on IEEE standards shall make it clear that his or her views should be considered the personal views of that individual rather than the formal position, explanation, or interpretation of the IEEE.

Comments for revision of IEEE Standards are welcome from any interested party, regardless of membership affiliation with IEEE. Suggestions for changes in documents should be in the form of a proposed change of text, together with appropriate supporting comments. Recommendations to change the status of a stabilized standard should include a rationale as to why a revision or withdrawal is required. Comments and recommendations on standards, and requests for interpretations should be addressed to:

Secretary, IEEE-SA Standards Board
445 Hoes Lane
Piscataway, NJ 08854
USA

Authorization to photocopy portions of any individual standard for internal or personal use is granted by The Institute of Electrical and Electronics Engineers, Inc., provided that the appropriate fee is paid to Copyright Clearance Center. To arrange for payment of licensing fee, please contact Copyright Clearance Center, Customer Service, 222 Rosewood Drive, Danvers, MA 01923 USA; +1 978 750 8400. Permission to photocopy portions of any individual standard for educational classroom use can also be obtained through the Copyright Clearance Center.

Introduction

This introduction is not part of IEEE Std C37.118.1-2011, IEEE Standard for Synchrophasor Measurements for Power Systems.

The original synchrophasor standard was IEEE Std 1344TM-1995 [B5].^a It was replaced by IEEE Std C37.118-2005 [B8]. This has now been split into two standards: IEEE Std 37.118.1-2011 (this standard), covering measurement provisions, and IEEE Std 37.118.2TM-2011 [B9], covering data communication. Both standards contain the previous material with updates and additional provisions.

In this standard, additional clarification is provided for the phasor and synchronized phasor definitions. The concepts of total vector error (TVE) and compliance tests are retained and expanded, tests over temperature variation have been added, and dynamic performance tests have been introduced. In addition, limits and characteristics of frequency measurement and rate of change of frequency (ROCOF) measurement have been developed. Annex C includes a system model intended to verify the ability to implement the required performance measures. The model is meant as a reference benchmark only; it is assumed that many real implementations will surpass this model in performance.

Phasors are used in many protection and data acquisition functions. By referencing them to a common time base they become comparable over a wide area of measurement. A synchrophasor is a phasor value obtained from voltage or current waveforms and precisely referenced to a common time base. Simultaneous measurement sets derived from synchronized phasors provide a vastly improved method for tracking power system dynamic phenomena for improved power system monitoring, protection, operation, and control.

The intent of any instrument connected to the power grid is to monitor power system parameters. The intent of this standard is to describe and quantify the performance of the *phasor measurement unit* (PMU) instrument deployed to monitor the power grid. The PMU extracts the parameters magnitude, phase angle, frequency, and ROCOF from the signals appearing at its input terminals. These signals may be corrupted by harmonic content, noise, and changes in state caused by system loads, and control and protective actions. Some examples are harmonics introduced by large non-linear loads, step changes in phase introduced by switched reactive elements, and random noise from arc furnaces. These artifacts complicate the process of measuring the generation and load characteristics at or near the system fundamental frequency.

The filtering associated with the computation of the synchrophasors rejects the undesirable signal components appearing at the PMU input within the limits provided by the filter attenuation. The frequency is computed as the first derivative of the synchrophasor phase angle, and ROCOF is computed as the second derivative of the same phase angle. These two quantities are less reliable measurements, particularly ROCOF, because they are more sensitive to undesirable components in the signal like harmonics, off-nominal components, or noise.

This standard presents a set of PMU performance requirements to ensure that compliant instruments will perform similarly when presented with this suite of test signals. The user shall be aware that in the presence of the previously mentioned undesirable components in the input signal, higher measurement errors could result. These errors may be substantial, particularly where higher order derivatives (such as ROCOF) are used. Signal processing alternatives may be employed to reduce or eliminate these errors. They are difficult to implement in a real-time environment and could adversely affect the measurement latency or the synchrophasor measurement response time. Alternatives are neither described nor evaluated in this document.

^aThe numbers in brackets correspond to those of the bibliography in Annex A.

Notice to users

Laws and regulations

Users of these documents should consult all applicable laws and regulations. Compliance with the provisions of this standard does not imply compliance to any applicable regulatory requirements. Implementers of the standard are responsible for observing or referring to the applicable regulatory requirements. IEEE does not, by the publication of its standards, intend to urge action that is not in compliance with applicable laws, and these documents may not be construed as doing so.

Copyrights

This document is copyrighted by the IEEE. It is made available for a wide variety of both public and private uses. These include both use, by reference, in laws and regulations, and use in private self-regulation, standardization, and the promotion of engineering practices and methods. By making this document available for use and adoption by public authorities and private users, the IEEE does not waive any rights in copyright to this document.

Updating of IEEE documents

Users of IEEE standards should be aware that these documents may be superseded at any time by the issuance of new editions or may be amended from time to time through the issuance of amendments, corrigenda, or errata. An official IEEE document at any point in time consists of the current edition of the document together with any amendments, corrigenda, or errata then in effect. In order to determine whether a given document is the current edition and whether it has been amended through the issuance of amendments, corrigenda, or errata, visit the IEEE Standards Association web site at <http://ieeexplore.ieee.org/xpl/standards.jsp>, or contact the IEEE at the address listed previously.

For more information about the IEEE Standards Association or the IEEE standards development process, visit the IEEE-SA web site at <http://standards.ieee.org>.

Errata

Errata, if any, for this and all other standards can be accessed at the following URL: <http://standards.ieee.org/findstds/errata/index.html>. Users are encouraged to check this URL for errata periodically.

Interpretations

Current interpretations can be accessed at the following URL: <http://standards.ieee.org/findstds/interps/index.html>.

Patents

Attention is called to the possibility that implementation of this standard may require use of subject matter covered by patent rights. By publication of this standard, no position is taken with respect to the existence or validity of any patent rights in connection therewith. The IEEE is not responsible for identifying Essential Patent Claims for which a license may be required, for conducting inquiries into the legal validity or scope of Patents Claims or determining whether any licensing terms or conditions provided in connection with submission of a Letter of Assurance, if any, or in any licensing agreements are reasonable or non-discriminatory. Users of this standard are expressly advised that determination of the validity of any patent rights, and the risk of infringement of such rights, is entirely their own responsibility. Further information may be obtained from the IEEE Standards Association.

Participants

At the time this standard was submitted to the IEEE-SA Standards Board for approval, the Synchrophasor Measurements for Power Systems Working Group had the following membership:

Kenneth Martin, *Chair*
Bogdan Kasztenny, *Vice Chair*

Mark Adamiak	Juan Gers	Krish Narendra
Scott Anderson	Allen Goldstein	Arun Phadke
Galina Antonova	Hank Hechun	Tevfik Sezi
Miroslav Begovic	Yi Hu	Veselin Skendzic
Gabriel Benmouyal	Mladen Kezunovic	Jerry Stenbakken
Gustavo Brunello	Harold Kirkham	Eric Udren
Bill Dickerson	Jay Murphy	John Wang

The following members of the individual balloting committee voted on this standard. Balloters may have voted for approval, disapproval, or abstention.

William J. Ackerman	Roger Hedding	Farnoosh Rahmatian
Mark Adamiak	Jerry Hohn	Michael Roberts
Eric Allen	C. Huntley	Charles Rogers
M. Victoria Alonso	Gerald Johnson	Miriam Sanders
Galina Antonova	Innocent Kamwa	Steven Sano
James Ariza	Bogdan Kasztenny	Bartien Sayogo
Jack Arnold	Yuri Khersonsky	Thomas Schossig
Ali Al Awazi	James Kinney	Robert Seitz
David Bassett	Joseph L. Koepfinger	Jose Antonio De La O Serna
Philip Beaumont	Jim Kulchisky	Gil Shultz
Kenneth Behrendt	Chung-Yiu Lam	Mark Simon
Oscar Bolado	Raluca Lascu	Veselin Skendzic
Gustavo Brunello	Kenneth Martin	James Smith
Arvind K. Chaudhary	Pierre Martin	Jerry Smith
Luis Coronado	John McDonald	Gary Stoedter
Randall Crellin	Michael McDonald	Charles Sufana
Gary Donner	Harish Mehta	Richard Taylor
Michael Dood	Gary Michel	William Taylor
Randall Dotson	Adi Mulawarman	Demetrios Tziouvaras
Gary Engmann	Jerry Murphy	Joe Uchiyama
Herbert Falk	R. Murphy	Eric Udren
Fredric Friend	Bruce Muschlitz	John Vergis
Vasudev S. Gharpure	Michael S. Newman	Iliia Voloh
Jeffrey Gilbert	Mohamed Omran	Roel Vries
Mietek Glinkowski	Dean Ouellette	John Wang
Jalal Gohari	Lorraine Padden	Kenneth White
Allen Goldstein	Donald Parker	Thomas Wiedman
Roman Graf	Mark Peterson	Ray Young
Stephen Grier	Robert Pettigrew	Jian Yu
Randall C. Groves	Bruce Pickett	Sergio Zimath

When the IEEE-SA Standards Board approved this standard on 7 December 2011, it had the following membership:

Richard H. Hulett, *Chair*
John Kulick, *Vice Chair*
Robert M. Grow, *Past Chair*
Judith Gorman, *Secretary*

Masayuki Ariyoshi
William Bartley
Ted Burse
Clint Chaplin
Wael Diab
Jean-Philippe Faure
Alexander Gelman
Paul Houz 

Jim Hughes
Joseph L. Koepfinger*
David J. Law
Thomas Lee
Hung Ling
Oleg Logvinov
Ted Olsen

Gary Robinson
Jon Walter Rosdahl
Sam Sciacca
Mike Seavey
Curtis Siller
Phil Winston
Howard L. Wolfman
Don Wright

*Member Emeritus

Also included are the following nonvoting IEEE-SA Standards Board liaisons:

Satish K. Aggarwal, *NRC Representative*
Richard DeBlasio, *DOE Representative*
Michael Janezic, *NIST Representative*

Don Messina
IEEE Standards Program Manager, Document Development

Soo H. Kim
IEEE Standards Project Manager

Contents

1. Overview	1
1.1 Scope	1
1.2 Purpose	1
1.3 General overview.....	2
1.4 Need for this standard.....	2
2. Normative references.....	3
3. Definitions, acronyms, and abbreviations	3
3.1 Definitions	3
3.2 Special terms.....	4
3.3 Acronyms and abbreviations	4
4. Synchrophasor measurement.....	5
4.1 Phasor definition.....	5
4.2 Synchrophasor definition.....	5
4.3 Measurement time synchronization	7
5. Synchrophasor measurement requirements and compliance verification.....	8
5.1 Synchrophasor estimation.....	8
5.2 Frequency and rate of change of frequency estimation	8
5.3 Measurement evaluation.....	9
5.4 Measurement reporting.....	10
5.5 Measurement compliance	12
Annex A (informative) Bibliography	24
Annex B (informative) Time tagging and dynamic response.....	25
Annex C (informative) Reference signal processing models	29
Annex D (informative) Time and synchronization communication	38
Annex E (informative) TVE evaluation and PMU testing.....	44
Annex F (informative) Generator voltage and power angle measurement.....	48

IEEE Standard for Synchrophasor Measurements for Power Systems

IMPORTANT NOTICE: This standard is not intended to ensure safety, security, health, or environmental protection. Implementers of the standard are responsible for determining appropriate safety, security, environmental, and health practices or regulatory requirements.

This IEEE document is made available for use subject to important notices and legal disclaimers. These notices and disclaimers appear in all publications containing this document and may be found under the heading “Important Notice” or “Important Notices and Disclaimers Concerning IEEE Documents.” They can also be obtained on request from IEEE or viewed at <http://standards.ieee.org/IPR/disclaimers.html>.

1. Overview

1.1 Scope

This standard is for synchronized phasor measurement systems in power systems. It defines a synchronized phasor (synchrophasor), frequency, and rate of change of frequency (ROCOF) measurements. It describes time tag and synchronization requirements for measurement of all three of these quantities. It specifies methods for evaluating these measurements and requirements for compliance with the standard under both static and dynamic conditions. It defines a *phasor measurement unit* (PMU), which can be a stand-alone physical unit or a functional unit within another physical unit. This standard does not specify hardware, software, or a method for computing phasors, frequency, or ROCOF.

1.2 Purpose

This standard defines synchronized phasor and frequency measurements in substations along with methods and requirements for measurement verification. Measurements compliant with the standard and taken at various locations in the power system can be readily and accurately combined for power system analysis and operations. Time tag and other essential associations are also described to facilitate communication and reliable data application. Communication and recording of phasor measurements are covered in other standards, such as the companion standard IEEE Std C37.118.2™-2011 [B9].¹

¹ The numbers in brackets correspond to those of the bibliography in Annex A.

1.3 General overview

This standard covers synchronized phasor measurements used in electric power systems. It defines the measurement, provides methods of quantifying the measurements, defines performance tests, and specifies acceptable limits. The following clauses are provided:

- Clause 1 provides the scope and needs for the standard.
- Clause 2 references other standards that are related or may be useful in the study and application of this standard.
- Clause 3 defines terms and abbreviations found in this standard.
- Clause 4 defines the measurement.
- Clause 5 defines measurement requirements, a method of quantifying the measurement, a test method, and accuracy limits.

Six informative annexes are also provided to clarify the standard and give supporting information, as follows:

- Annex A is a bibliography.
- Annex B explores the effects of time tagging and transient response relevant to this measurement technique.
- Annex C provides the algorithms that were used to confirm the performance requirements.
- Annex D discusses time synchronization.
- Annex E explains the total vector error (TVE) concept of measurement quality and gives plots of error results.
- Annex F describes two methods that can be used for measuring the internal voltages and power angles of generators.

1.4 Need for this standard

The 2005 version of the standard, commonly followed by equipment manufacturers and system integrators, specifies the performance of phasor measurements only under steady-state conditions. Synchrophasor applications, particularly during severe system disturbances, will utilize dynamic synchronized measurements. This revision of the standard extends the synchrophasor definition and specifies measurement requirements and test conditions to include practical dynamic power system conditions.

The original synchrophasor standard, IEEE Std 1344TM-1995 [B5], and its successor, IEEE Std C37.118TM-2005 [B8], provide for reporting of system frequency and rate of change of system frequency. These quantities are not defined, however, and no measurement requirements are mandated.

This revision provides definition and measurement requirements for power system frequency and ROCOF under practical power system conditions. A number of issues in the standard have been identified that require clarification or modification. This revision also separates the measurement and communication subclauses of IEEE Std C37.118-2005 [B8] into individual standards. This simplifies widespread adoption and aids deployment by allowing freer use of other standards for synchrophasor communication.

2. Normative references

The following referenced documents are indispensable for the application of this document (i.e., they must be understood and used, so each referenced document is cited in text and its relationship to this document is explained). For dated references, only the edition cited applies. For undated references, the latest edition of the referenced document (including any amendments or corrigenda) applies.

IEEE Std 754™-1985, IEEE Standard for Binary Floating-Point Arithmetic.^{2, 3}

3. Definitions, acronyms, and abbreviations

For the purposes of this document, the following terms and definitions apply. The *IEEE Standards Dictionary: Glossary of Terms & Definitions* [B2] should be consulted for terms not defined in this clause.⁴

3.1 Definitions

anti-aliasing: The process of filtering a signal before sampling to remove components of that signal whose frequency is equal to or greater than the Nyquist frequency (one-half the sample rate). If not removed, these signal components would appear as a lower frequency component (an alias).

Coordinated Universal Time (UTC): (Initials are ordered based on French language.) The time of day at the Earth's prime meridian (0° longitude). It is distributed by various media, including the Global Positioning System (GPS) system.

data concentrator (DC): A device that combines data from several measurement devices.

frequency error (FE): The measure of error between the theoretical frequency and the measured frequency for the given instant of time.

Global Positioning System (GPS): A U.S. Department of Defense (DoD) navigation system that uses a constellation of 24 satellites broadcasting a precision signal for location and time synchronization. Basic time synchronization accuracy is ± 0.2 microseconds (μs).

IEEE floating point: A 32-bit representation of a real number.

NOTE—This definition is in accordance with IEEE Std 754-1985.⁵

leap second: A positive or negative one-second adjustment to the Coordinated Universal Time (UTC) that keeps it close to mean solar time.

Nyquist frequency: A frequency that is one-half the sampling frequency of a discrete signal processing system.

Nyquist rate: A sampling rate that is twice the bandwidth of a band-limited signal. It is the minimum sample rate that will result in an alias-free representation of a signal. It must therefore be greater than twice the highest frequency component in the signal.

² IEEE publications are available from the Institute of Electrical and Electronics Engineers, 445 Hoes Lane, Piscataway, NJ 08854, USA (<http://standards.ieee.org>).

³ The IEEE standards or products referred to in Clause 2 are trademarks owned by the Institute of Electrical and Electronics Engineers, Incorporated.

⁴ The *IEEE Standards Dictionary: Glossary of Terms & Definitions* is available at <http://shop.ieee.org/>.

⁵ Information on references can be found in Clause 2.

phasor: A complex equivalent of a sinusoidal wave quantity such that the complex modulus is the cosine wave amplitude, and the complex angle (in polar form) is the cosine wave phase angle.

phasor data concentrator (PDC): A data concentrator (DC) used in phasor measurement systems.

rate of change of frequency (ROCOF) error (RFE): The measure of error between the theoretical ROCOF and the measured ROCOF for the given instant of time.

synchronism: The state in which connected alternating-current systems, machines, or a combination operate at the same frequency, and in which the phase angle displacements between voltages in them are constant or vary about a steady and stable average value.

synchronized phasor or synchrophasor: A phasor calculated from data samples using a standard time signal as the reference for the measurement.

NOTE—In this standard, the phasors from remote sites have a defined common phase relationship.

total vector error (TVE): The measure of error between the theoretical phasor value of the signal being measured and the phasor estimate.

NOTE—See 5.2.

3.2 Special terms

frame: In this standard, a *data frame* or a *frame of data* is a set of synchrophasor, frequency, and ROCOF measurements that corresponds to the same time stamp. The term *frame* is used to differentiate it from *samples*, which are understood as points on an analog waveform.

phasor measurement unit (PMU): In this standard, a device that produces synchronized phasor, frequency, and ROCOF estimates from voltage and/or current signals and a time synchronizing signal. Note that the same device may perform other functions and include another functional name [e.g., the device may also record power system waveforms and be called a *digital fault recorder (DFR)*].

3.3 Acronyms and abbreviations

BCD	binary coded decimal
DoD	U.S. Department of Defense
f_0	system nominal frequency, either 50 Hz or 60 Hz
f_{in}	Input frequency of the fundamental; this is the frequency of the measurement input that is normally at or very close to nominal (50 Hz or 60 Hz) but may vary considerably during major disturbances or testing.
fps	frames per second, the rate that frames of synchrophasor data are transmitted
F_s	frequency of measurement data reporting, in frames per second (fps)
IRIG-B	InterRange Instrumentation Group Time Code Format B
PPS	pulse per second
rms	root mean square

ROCOF	rate of change of frequency
SBS	straight binary seconds
SCADA	Supervisory Control and Data Acquisition
SOC	second of century
THD	total harmonic distortion

4. Synchrophasor measurement

4.1 Phasor definition

Phasor representation of sinusoidal signals is commonly used in ac power system analysis. The sinusoidal waveform defined in Equation (1):

$$x(t) = X_m \cos(\omega t + \phi) \quad (1)$$

is commonly represented as the phasor as shown in Equation (2):

$$\begin{aligned} \mathbf{X} &= (X_m/\sqrt{2}) e^{j\phi} \\ &= (X_m/\sqrt{2}) (\cos \phi + j \sin \phi) \\ &= X_r + jX_i \end{aligned} \quad (2)$$

where the magnitude is the root-mean-square (rms) value, $X_m/\sqrt{2}$, of the waveform, and the subscripts r and i signify real and imaginary parts of a complex value in rectangular components. The value of ϕ depends on the time scale, particularly where $t = 0$. It is important to note this phasor is defined for the angular frequency ω ; evaluation with other phasors must be done with the same time scale and frequency.

4.2 Synchrophasor definition

The *synchrophasor* representation of the signal $x(t)$ in Equation (1) is the value \mathbf{X} in Equation (2) where ϕ is the instantaneous phase angle relative to a cosine function at the nominal system frequency synchronized to UTC.

Under this definition, ϕ is the offset from a cosine function at the nominal system frequency synchronized to UTC. A cosine has a maximum at $t = 0$, so the synchrophasor angle is 0 degrees when the maximum of $x(t)$ occurs at the UTC second rollover (1 PPS time signal), and -90 degrees when the positive zero crossing occurs at the UTC second rollover (sin waveform). Figure 1 illustrates the phase angle/UTC time relationship.

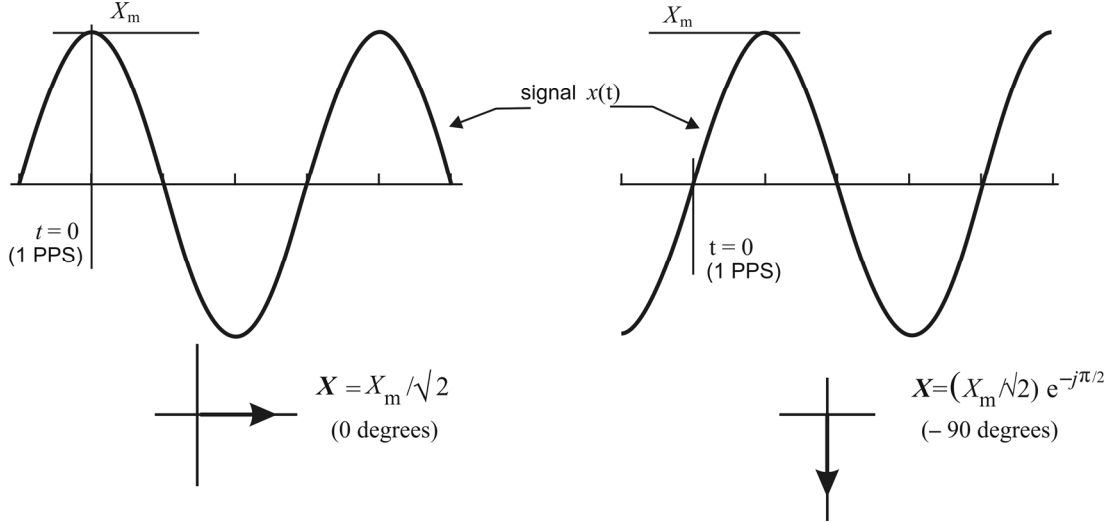

Figure 1—Convention for synchrophasor representation

The sinusoid is shown in Equation (3):

$$x(t) = X_m \cos(\omega_0 t + \phi) = X_m \cos(2\pi f_0 t + \phi) \quad (3)$$

where f_0 is the nominal angular system frequency (50 Hz or 60 Hz) directly represented by the phasor in Equation (2). In the general case where the amplitude is a function of time $X_m(t)$ and the sinusoid frequency is also a function of time $f(t)$, we can define the function $g = f - f_0$ where f_0 is the nominal frequency and g is the difference between the actual and nominal frequencies (note that g will also be a function of time, e.g., $g(t) = f(t) - f_0$). The sinusoid can then be written as shown in Equation (4):

$$\begin{aligned} x(t) &= X_m(t) \cos(2\pi \int f dt + \phi) \\ &= X_m(t) \cos(2\pi (f_0 + g) dt + \phi) \\ &= X_m(t) \cos(2\pi f_0 t + (2\pi \int g dt + \phi)) \end{aligned} \quad (4)$$

The synchrophasor representation for this waveform is shown in Equation (5):

$$\mathbf{X}(t) = (X_m(t)/\sqrt{2}) e^{j(2\pi \int g dt + \phi)} \quad (5)$$

For the special case where $X_m(t) = X_m$ is constant and $g = \Delta f$ is a constant offset from the nominal frequency, $\int g(t) dt = \int \Delta f dt = \Delta f t$ so the synchrophasor is simply as shown in Equation (6):

$$\mathbf{X}(t) = (X_m/\sqrt{2}) e^{j(2\pi \Delta f t + \phi)} \quad (6)$$

that will rotate at the uniform rate Δf , the difference between the actual and off-nominal frequency.

This concept is illustrated in Figure 2. Consider that a sinusoid off-nominal system frequency is observed at intervals $\{0, T_0, 2T_0, 3T_0, \dots, nT_0, \dots\}$ where $T_0 = 1/f_0$ (the nominal power system period) and the corresponding phasor representations are $\{\mathbf{X}_0, \mathbf{X}_1, \mathbf{X}_2, \mathbf{X}_3, \dots, \mathbf{X}_n, \dots\}$. If the sinusoid frequency $f \neq f_0$ and $f < 2f_0$, the observed phasor will have a constant magnitude, but the phase angles of the sequence of phasors $\{\mathbf{X}_0, \mathbf{X}_1, \mathbf{X}_2, \mathbf{X}_3, \dots, \mathbf{X}_n, \dots\}$ will change uniformly at a rate $2\pi(f - f_0)T_0$, as illustrated. If these values were reported over time, they would continuously increase until they reached 180 degrees where they would wrap around to -180 degrees and continue to increase as shown in Figure 3 (synchrophasors are commonly reported in angles -180 degrees to $+180$ degrees rather than 0 to 360 degrees).

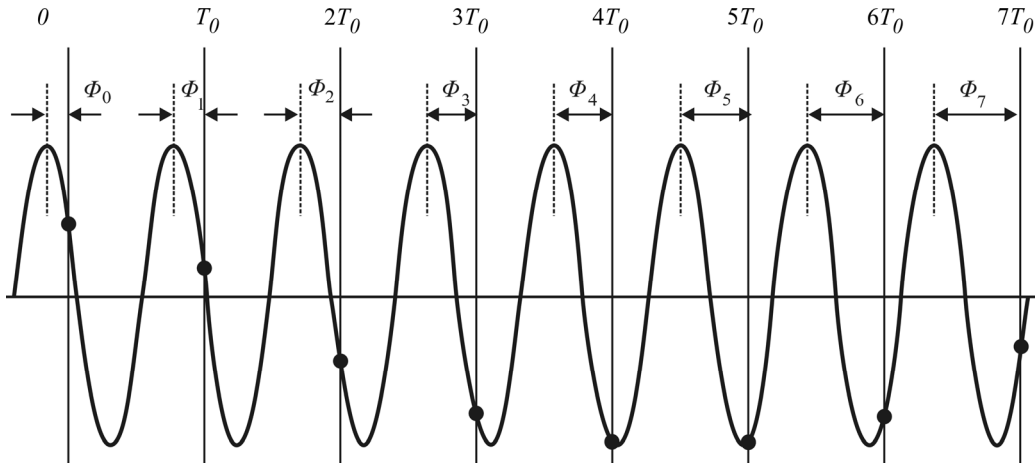

Figure 2—A sinusoid with a frequency $f > f_0$ is observed at instants that are T_0 seconds apart—the phase angle ϕ increases uniformly in relation to the frequency difference, $f - f_0$

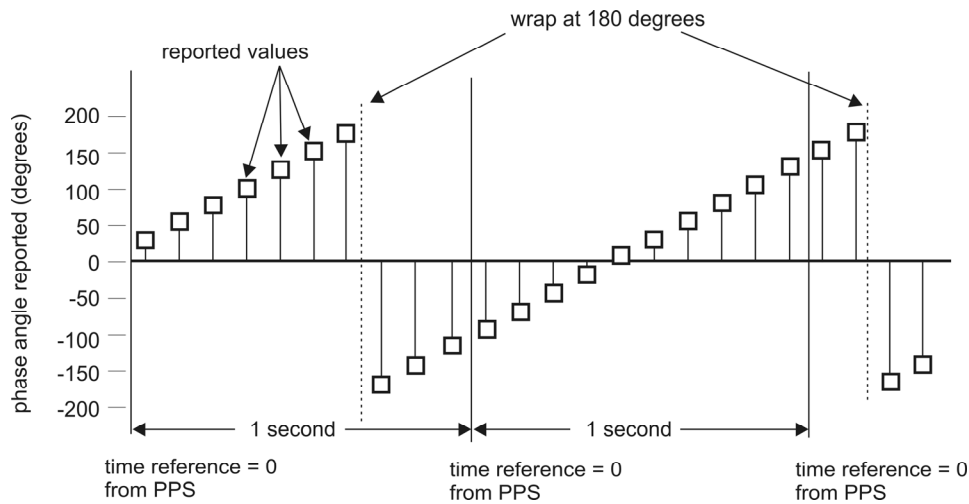

Figure 3—Sampling a power frequency sinusoid at off-nominal frequency

Several details of the synchrophasor definition shall be emphasized. All measurements are on a common time base and related to a common frequency, so the phase angle measurements are directly comparable. Differences in the actual frequency are included in the phase angle estimation. The synchrophasor estimate also includes the effects of all other signal contributions such as oscillations and local frequency swings. Synchrophasors are functions of time and will change from one value to the next unless the signal is a pure sinusoid at nominal system frequency. A precise time reference (clock) is required to provide the UTC time to determine the phase angle ϕ .

4.3 Measurement time synchronization

The PMU shall be capable of receiving time from a reliable and accurate source, such as the Global Positioning System (GPS), that can provide time traceable to UTC with sufficient accuracy to keep the *total vector error* (TVE), the *frequency error* (FE), and the *rate of change of frequency* (ROCOF) error (RFE) within the required limits. All measurements shall be synchronized to UTC time with accuracy sufficient to meet the requirements of this standard. Note that a time error of 1 μ s corresponds to a synchrophasor phase

error of 0.022 degrees for a 60 Hz system and 0.018 degrees for a 50 Hz system. A phase error of 0.57 degrees (0.01 radian) will by itself cause 1% TVE as defined in Equation (12). This corresponds to a time error of $\pm 26 \mu\text{s}$ for a 60 Hz system and $\pm 31 \mu\text{s}$ for a 50 Hz system. A time source FE of 0.083 MHz in a 60 Hz system or 0.1 MHz in a 50 Hz system will cause the maximum allowed steady-state FE of 0.005 Hz. Similarly, a time source with a varying frequency will cause a corresponding error in ROCOF (the relationship is not as direct as those above). A time source that reliably provides time, frequency, and frequency stability at least 10 times better than these values corresponding to 1% TVE is highly recommended. The time source shall also provide an indication of traceability to UTC and leap second changes.

For each measurement, the PMU shall assign a time tag that includes the time and time quality at the time of measurement. The time tag shall accurately resolve time of measurement to at least $1 \mu\text{s}$ within a specified 100 year period. The time status shall include time quality that clearly indicates traceability to UTC, time accuracy, and leap second status. Time and time quality for reporting and recording shall be derived from the PMU time tag and converted to the format and content as required.

5. Synchrophasor measurement requirements and compliance verification

5.1 Synchrophasor estimation

A PMU shall calculate and be capable of reporting synchrophasor estimates as defined and described in Clause 4. The estimates shall include single phase or positive sequence synchrophasors, or both. Provision shall be made for the user selection of the measured values. Measurement accuracy, reporting times, and evaluation criteria are given in this clause. Note that measurements are actually estimates of a certain value; the terms *measurement* and *estimate* are used somewhat interchangeably in this standard.

5.2 Frequency and rate of change of frequency estimation

A PMU shall calculate and be capable of reporting frequency and ROCOF. For this measurement, the following standard definitions shall be used. Given a sinusoidal signal, as shown in Equation (7):

$$x(t) = X_m \cos [\psi(t)] \quad (7)$$

Frequency is defined as shown in Equation (8):

$$f(t) = \frac{1}{2\pi} \frac{d\psi(t)}{dt} \quad (8)$$

The ROCOF is defined shown in Equation (9):

$$\text{ROCOF}(t) = \frac{df(t)}{dt} \quad (9)$$

Synchrophasors are always computed in relation to the system nominal frequency (f_0). If the cosine argument is represented as $\psi(t) = \omega_0 t + \varphi(t) = 2\pi f_0 t + \varphi(t) = 2\pi [f_0 t + \varphi(t)/2\pi]$, the formula for frequency becomes, as shown in Equation (10):

$$f(t) = f_0 + d[\varphi(t)/2\pi]/dt = f_0 + \Delta f(t) \quad (10)$$

where $\Delta f(t)$ is the deviation of frequency from nominal, and, as shown in Equation (11):

$$\text{ROCOF}(t) = d^2[\varphi(t)/2\pi]/dt^2 = d(\Delta f(t))/dt \quad (11)$$

Frequency in phasor measurements may be reported as the actual frequency $f(t)$ or the deviation of frequency from nominal, $\Delta f(t)$. In steady-state conditions, $\Delta f(t)$ can be represented as a scalar number Δf .

5.3 Measurement evaluation

5.3.1 Synchrophasor measurement evaluation

The theoretical values of a synchrophasor representation of a sinusoid and the values obtained from a PMU may include differences in both amplitude and phase. While they could be separately specified, the amplitude and phase differences are considered together in this standard in the quantity called *total vector error* (TVE). TVE is an expression of the difference between a “perfect” sample of a theoretical synchrophasor and the estimate given by the unit under test at the same instant of time. The value is normalized and expressed as per unit of the theoretical phasor.

TVE is defined in Equation (12):

$$\text{TVE}(n) = \sqrt{\frac{(\hat{X}_r(n) - X_r(n))^2 + (\hat{X}_i(n) - X_i(n))^2}{(X_r(n))^2 + (X_i(n))^2}} \quad (12)$$

Where $\hat{X}_r(n)$ and $\hat{X}_i(n)$ are the sequences of estimates given by the unit under test, and $X_r(n)$ and $X_i(n)$ are the sequences of theoretical values of the input signal at the instants of time (n) assigned by the unit to those values. The values $X_r(n)$ and $X_i(n)$ can be determined in closed form in certain well-defined situations, such as constant frequency or phase offsets, and these situations are explored in this standard.

Synchrophasor measurements shall be evaluated using the TVE criterion of Equation (12).

5.3.2 Frequency and ROCOF measurement evaluation

Frequency and ROCOF measurements shall be evaluated using the following definitions. With these criteria, frequency, and ROCOF errors are the absolute value of the difference between the theoretical values and the estimated values given in Hz and Hz/s respectively. See Equation (13) and Equation (14).

$$\text{Frequency measurement error:} \quad \text{FE} = |f_{\text{true}} - f_{\text{measured}}| = |\Delta f_{\text{true}} - \Delta f_{\text{measured}}| \quad (13)$$

$$\text{ROCOF measurement error:} \quad \text{RFE} = |(df/dt)_{\text{true}} - (df/dt)_{\text{measured}}| \quad (14)$$

The measured and true values are for the same instant of time, which will be given by the time tag of the estimated values.

5.3.3 Measurement response time and delay time

Measurement response time is the time to transition between two steady-state measurements before and after a step change is applied to the input. It shall be determined as the difference between the time that the measurement leaves a specified accuracy limit and the time it reenters and stays within that limit when a step change is applied to the PMU input. This shall be measured by applying a positive or negative step change in phase or magnitude to the PMU input signal. The input signal shall be held at a steady-state condition before and after the step change. The only input signal change during this test shall be the

parameter(s) that have been stepped. Accuracy limits are the TVE, FE, and RFE values for the phasor, frequency, and ROCOF measurements, respectively. The limits are specified in 5.5.8. Note that the response time is determined from the accuracy evaluation of the measurements, not step time or the stepped parameters themselves.

Measurement delay time is defined as the time interval between the instant that a step change is applied to the input of a PMU and measurement time that the stepped parameter achieves a value that is halfway between the initial and final steady-state values. Both the step time and measurement time are measured on the UTC time scale. This measurement shall be determined by applying a positive or negative step change in phase or magnitude to the PMU input signal. The input signal shall be held at a steady-state condition before and after the step change. The only input signal change during this test shall be the parameter(s) that have been stepped. Note this measurement requires comparing a step in magnitude with the magnitude measurement and a step in phase angle with the phase angle measurement.

The purpose of evaluating the measurement delay time is to verify that the time tagging of the synchrophasor measurement (measurement time) has been properly compensated for the filtering system group delay. It is expected that the time tag as provided by the PMU has been properly compensated for the filtering system group delay, so that the delay will be near zero.

A step change is instantaneous by definition; however, if the slewing rate of an applied signal is slow enough to introduce significant uncertainty in the time of application, the time of the midpoint of the step shall be used as the step time.

5.3.4 Measurement reporting latency

Latency in measurement reporting is the time delay from when an event occurs on the power system to the time that it is reported in data. This latency includes many factors, such as the window over which data is gathered to make a measurement, the estimation method, measurement filtering, the PMU processing time, and where the event occurs within the reporting interval. The reporting rate and performance class are often the largest factors, since these will determine the measurement window, filtering, and the length of the interval over which an event will be reported.

For purposes of this standard, PMU reporting latency is defined as the maximum time interval between the data report time as indicated by the data time stamp, and the time when the data becomes available at the PMU output (denoted by the first transition of the first bit of the output message at the communication interface point).

5.3.5 Measurement and operational errors

The PMU shall assign a flag to each measurement to indicate internal problems encountered during the measurement process. This flag shall include errors detectable by the PMU including A/D errors, memory overflow, calculation overflow and any other condition that could cause an error in the measurement. When IEEE C37.118.2 reporting is used, this flag shall be reported as bit 14, PMU error, in the status word. (Under this requirement all measurement and operational error conditions shall be combined into a single error indication bit.)

5.4 Measurement reporting

Synchrophasor, frequency, and ROCOF estimates shall be made so they can be reported at a constant rate, F_s , which is an integer number of times per second when the rate is greater than one per second, or an integer number of seconds between measurements when the measurement rate is equal to or slower than one per second. All three measurements shall be made and reported for the same reporting time. The

reporting times shall be evenly spaced so the intervals between reports are all the same. The PMU may make other measurements synchronously with these specified measurements, such as Boolean status, waveform sampling, or other calculated data.

5.4.1 Reporting rates

The PMU shall support data reporting (by recording or output) at sub-multiples of the nominal power-line (system) frequency. Required rates for 50 Hz and 60 Hz systems are listed in the Table 1:

Table 1—Required PMU reporting rates

System frequency	50 Hz			60 Hz					
Reporting rates (F_s —frames per second)	10	25	50	10	12	15	20	30	60

The actual rate to be used shall be user selectable. Support for other reporting rates is permissible, and including higher rates like 100/s or 120/s or rates lower than 10/s such as 1/s is encouraged. Note that rates lower than 10/s are not subject to the dynamic requirements of this standard (see 5.5.2). This means no filtering is required, so lower rate data (< 10/s) can be provided directly by selecting every nth sample from a higher rate stream.

5.4.2 Reporting times

For a reporting rate N frames per second (fps) where N is a positive integer, the reporting times shall be evenly spaced through each second with frame number 0 (numbered 0 thru N-1) coincident with the UTC second rollover (e.g., coincident with a 1 PPS provided by GPS). These reporting times (time tags) are to be used for determining the instantaneous values of the synchrophasor as defined in 4.2. This is illustrated in Figure 2 where the reporting times are at 0, T_0 , $2T_0$, $3T_0$, $4T_0$, etc. If rates lower than 1/s are used, there shall be one report on the hour (xx:00:00) and evenly spaced thereafter with an integer number of seconds between reports according to the chosen rate in the absence of leap seconds. If a leap second occurs, the last interval in the hour shall be shorter or longer by that leap second.

5.4.3 Example results

Table 2 gives the synchrophasor values as defined in Equation (1) for the waveforms shown in Figure 2. The values are derived for a 10 fps reporting rate with a system frequency of 50 Hz and 60 Hz. Synchrophasor values are shown for base phase angles of 0 degrees and -90 degrees at the 1 PPS time mark as shown in Figure 1 for both 50 Hz and 60 Hz, and then 51 Hz and 61 Hz signals. The values in this example depend only on the magnitude, the reporting rate, and the signal frequency relative to the system frequency, so they are identical for 50 Hz and 60 Hz systems.

Table 2—Table of synchrophasor values at a 10 fps reporting rate

Time	Fractional time		Synchrophasor values for: 50 Hz frequency—50 Hz system 60 Hz frequency—60 Hz system		Synchrophasor values for: 51 Hz frequency—50 Hz system 61 Hz frequency—60 Hz system	
	Frame number	Fractional second	Synchrophasor (0 degrees)	Synchrophasor (-90 degrees)	Synchrophasor (0 degrees)	Synchrophasor (-90 degrees)
k-1	9	0.900000	$X_m/\sqrt{2}, \angle 0^\circ$	$X_m/\sqrt{2}, \angle -90^\circ$	$X_m/\sqrt{2}, \angle -36^\circ$	$X_m/\sqrt{2}, \angle -126^\circ$
k	0	0.000000	$X_m/\sqrt{2}, \angle 0^\circ$	$X_m/\sqrt{2}, \angle -90^\circ$	$X_m/\sqrt{2}, \angle 0^\circ$	$X_m/\sqrt{2}, \angle -90^\circ$
k	1	0.100000	$X_m/\sqrt{2}, \angle 0^\circ$	$X_m/\sqrt{2}, \angle -90^\circ$	$X_m/\sqrt{2}, \angle 36^\circ$	$X_m/\sqrt{2}, \angle -54^\circ$
k	2	0.200000	$X_m/\sqrt{2}, \angle 0^\circ$	$X_m/\sqrt{2}, \angle -90^\circ$	$X_m/\sqrt{2}, \angle 72^\circ$	$X_m/\sqrt{2}, \angle -18^\circ$
k	3	0.300000	$X_m/\sqrt{2}, \angle 0^\circ$	$X_m/\sqrt{2}, \angle -90^\circ$	$X_m/\sqrt{2}, \angle 108^\circ$	$X_m/\sqrt{2}, \angle 18^\circ$
k	4	0.400000	$X_m/\sqrt{2}, \angle 0^\circ$	$X_m/\sqrt{2}, \angle -90^\circ$	$X_m/\sqrt{2}, \angle 144^\circ$	$X_m/\sqrt{2}, \angle 54^\circ$
k	5	0.500000	$X_m/\sqrt{2}, \angle 0^\circ$	$X_m/\sqrt{2}, \angle -90^\circ$	$X_m/\sqrt{2}, \angle 180^\circ$	$X_m/\sqrt{2}, \angle 90^\circ$
k	6	0.600000	$X_m/\sqrt{2}, \angle 0^\circ$	$X_m/\sqrt{2}, \angle -90^\circ$	$X_m/\sqrt{2}, \angle -144^\circ$	$X_m/\sqrt{2}, \angle 126^\circ$
k	7	0.700000	$X_m/\sqrt{2}, \angle 0^\circ$	$X_m/\sqrt{2}, \angle -90^\circ$	$X_m/\sqrt{2}, \angle -108^\circ$	$X_m/\sqrt{2}, \angle 162^\circ$
k	8	0.800000	$X_m/\sqrt{2}, \angle 0^\circ$	$X_m/\sqrt{2}, \angle -90^\circ$	$X_m/\sqrt{2}, \angle -72^\circ$	$X_m/\sqrt{2}, \angle -162^\circ$
k	9	0.900000	$X_m/\sqrt{2}, \angle 0^\circ$	$X_m/\sqrt{2}, \angle -90^\circ$	$X_m/\sqrt{2}, \angle -36^\circ$	$X_m/\sqrt{2}, \angle -126^\circ$
k+1	0	0.000000	$X_m/\sqrt{2}, \angle 0^\circ$	$X_m/\sqrt{2}, \angle -90^\circ$	$X_m/\sqrt{2}, \angle 0^\circ$	$X_m/\sqrt{2}, \angle -90^\circ$

5.5 Measurement compliance

5.5.1 Introduction

To be compliant with this standard, a PMU shall provide synchrophasor, frequency, and ROCOF measurements that meet the requirements in this subclause. These requirements shall be met at all times and under all configurations whether the PMU function is a stand-alone physical unit or included as part of a multifunction unit. This subclause details the requirements and conditions under which those requirements shall be met. The first subclauses describe the test equipment needs and conditions for test. The following subclauses describe the test conditions and requirements for steady-state and dynamic measurement conditions.

5.5.2 Performance classes

Compliance with the requirements shall be evaluated by class of performance. This standard defines two classes of performance: P class and M class.

P class is intended for applications requiring fast response and mandates no explicit filtering. The letter P is used since protection applications require fast response.

M class is intended for applications that could be adversely effected by aliased signals and do not require the fastest reporting speed. The letter M is used since analytic measurements often require greater precision but do not require minimal reporting delay.

However these two class designations do not indicate that either class is adequate or required for a particular application. The user must choose a performance class that matches the requirements of each application.

All compliance requirements are specified by performance class. A PMU shall meet all the requirements as specified for a class, in order to be considered as compliant with this standard for that class. If the vendor provides both P and M class performance, these shall be user selectable.

5.5.3 Compliance verification

A calibration device used to verify performance in accordance with this subclause shall be traceable to national standards, and have a *test uncertainty ratio* of at least four (4) compared with these test requirements (for example, provide a TVE measurement within 0.25% where TVE is 1%). In cases where there is no national standard available for establishing traceability, a detailed error analysis shall be performed to demonstrate compliance with these requirements.

Documentation shall be provided by any vendor claiming compliance with this standard that shall include the following information:

- a) Performance class
- b) Measurements that meet this class of performance
- c) Test results demonstrating performance
- d) Equipment settings that were used in testing
- e) Environmental conditions during the testing
- f) Error analysis if the verification system is based on an error analysis as previously called for

Compliance verification is by PMU and class of performance. A PMU verified for a particular performance class shall meet all performance requirements specified for that class at all required reporting rates.

5.5.4 Reference and test conditions

All compliance tests are to be performed with all parameters set to standard reference conditions, except those being varied as specified for the test. The reference condition specified for each test is the value of the quantity being tested when not being varied. Only the parameters specified for each requirement shall be varied as the effects shall be considered independent. Reference conditions for all tests are as follows:

- a) Voltage at nominal
- b) Current at nominal
- c) Frequency at nominal
- d) Voltage, current, phase, and frequency constant
- e) Signal total harmonic distortion (THD) < 0.2% of the fundamental
- f) All interfering signals < 0.2% of the fundamental

Measurements at reporting rates (F_s) lower than 10/s shall not be subject to dynamic performance requirements. Such measurements shall be subject to all steady-state requirements (Table 3) except out-of-band rejection. This paragraph applies to all performance classes.

Unless otherwise specified, all testing to certify compliance shall be performed at standard laboratory test conditions that include the following:

- a) Temperature $23\text{ }^{\circ}\text{C} \pm 3\text{ }^{\circ}\text{C}$
- b) Humidity < 90%

Unless otherwise specified, the TVE, FE, and RFE for each performance requirement shall be the average, rms, or maximum value observed over a minimum of 5 s of test duration. Each test specifies whether the average, rms, or maximum value shall be used, and whether the period of observation shall be longer or shorter than 5 s. Note that some tests do not allow continued measurements at a specific value and specific methods are described with the test.

In the following subclauses, f_{in} is the frequency of the fundamental signal component. It is normally 50 Hz or 60 Hz, but in the course of testing may be varied from nominal. Also, f_0 always represents the nominal frequency, exactly 50 Hz or 60 Hz. Similarly, $\omega_0 = 2\pi f_0$ always represents the nominal frequency in radians/s.

5.5.5 Steady-state compliance

Steady-state compliance shall be confirmed by comparing the synchrophasor, frequency, and ROCOF estimates obtained under steady-state conditions to the corresponding theoretical values of X_r , X_i , F , and ROCOF. Steady-state conditions are where X_m , ω , and ϕ of the test signal, and all other influence quantities are fixed for the period of the measurement. (Note that for off-nominal frequencies, the measured phase angle will change even though the test signal phase ϕ is constant.) The same tests are used for phasor and frequency/ROCOF measurements but the tables of requirements are separated for clarity.

Table 3—Steady-state synchrophasor measurement requirements

Influence quantity	Reference condition	Minimum range of influence quantity over which PMU shall be within given TVE limit			
		P class		M class	
		Range	Max TVE (%)	Range	Max TVE (%)
Signal frequency range— f_{dev} (test applied nominal + deviation: $f_0 \pm f_{dev}$)	$F_{nominal}$ (f_0)	± 2.0 Hz	1	± 2.0 Hz for $F_s < 10$ $\pm F_s/5$ for $10 \leq F_s < 25$ ± 5.0 Hz for $F_s \geq 25$	1
The signal frequency range tests above are to be performed over the given ranges and meet the given requirements at three temperatures: T = nominal (~ 23 °C), T = 0 °C, and T = 50 °C					
Signal magnitude—Voltage	100% rated	80% to 120% rated	1	10% to 120% rated	1
Signal magnitude—Current	100% rated	10% to 200% rated	1	10% to 200% rated	1
Phase angle with $ f_{in} - f_0 < 0.25$ Hz (See NOTE 1)	Constant or slowly varying angle	$\pm\pi$ radians	1	$\pm\pi$ radians	1

Table 3—Steady-state synchrophasor measurement requirements (continued)

Influence quantity	Reference condition	Minimum range of influence quantity over which PMU shall be within given TVE limit			
		P class		M class	
		Range	Max TVE (%)	Range	Max TVE (%)
Harmonic distortion (single harmonic)	<0.2% (THD)	1%, each harmonic up to 50th	1	10%, each harmonic up to 50th	1
Out-of-band interference as described below (See NOTES 2 and 3)	<0.2% of input signal magnitude		None	10% of input signal magnitude for $F_s \geq 10$. No requirement for $F_s < 10$.	1.3
<p>Out-of-band interference testing: The passband at each reporting rate is defined as $f - f_0 < F_s/2$. An interfering signal outside the filter passband is a signal at frequency f where: $f - f_0 \geq F_s/2$</p> <p>For test the input test signal frequency f_{in} is varied between f_0 and $\pm (10\%)$ of the Nyquist frequency of the reporting rate.</p> <p>That is: $f_0 - 0.1 (F_s/2) \leq f_{in} \leq f_0 + 0.1 (F_s/2)$</p> <p>where</p> <p>$F_s$ = phasor reporting rate f_0 = nominal system frequency f_{in} = fundamental frequency of the input test signal</p>					
<p>NOTE 1—The phase angle test can be performed with the input frequency f_{in} offset from f_0 where $f_{in} - f_0 < 0.25$ Hz. This provides a slowly varying phase angle that simplifies compliance verification without causing significant other effects.</p> <p>NOTE 2—A signal whose frequency exceeds the Nyquist rate for the reporting rate F_s can alias into the passband. The test signal described for the out-of-band interference test verifies the effectiveness of the PMU anti-alias filtering. The test signal shall include those frequencies outside of the bandwidth specified above that cause the greatest TVE.</p> <p>NOTE 3—Compliance with out-of-band rejection can be confirmed by using a single frequency sinusoid added to the fundamental power signal at the required magnitude level. The signal frequency is varied over a range from below the passband (at least down to 10 Hz) and from above the passband up to the second harmonic ($2 \times f_0$). If the positive sequence measurement is being tested, the interfering signal is a positive sequence.</p>					

Table 4—Steady-state frequency and ROCOF measurement requirements

Influence quantity	Reference condition	Error requirements for compliance			
		P class		M class	
Signal frequency	Frequency = f_0 (f_{nominal}) Phase angle constant	Range: $f_0 \pm 2.0$		Range: $f_0 \pm 2.0$ Hz for $F_s \leq 10$ $\pm F_s/5$ for $10 \leq F_s < 25$ ± 5.0 Hz for $F_s \geq 25$	
		Max FE	Max RFE	Max FE	Max RFE
		0.005 Hz	0.01 Hz/s	0.005 Hz	0.01 Hz/s
Harmonic distortion (same as Table 3) (single harmonic)	<0.2% THD	1% each harmonic up to 50th		10% each harmonic up to 50th	
		Max FE	Max RFE	Max FE	Max RFE
	$F_s > 20$	0.005 Hz	0.01 Hz/s	0.025 Hz	6 Hz/s
	$F_s \leq 20$	0.005 Hz	0.01 Hz/s	0.005 Hz	2 Hz/s
Out-of-band interference (same as Table 3)	<0.2% of input signal magnitude	No requirements		Interfering signal 10% of signal magnitude	
				Max FE	Max RFE
		None	None	0.01 Hz	0.1 Hz/s

Note that frequency and ROCOF are required to comply with the measurement limits only over the same range of frequencies specified for phasors. However most frequency and ROCOF measurements will operate successfully over a much wider range. Vendors are encouraged to extend their measurement reporting over the widest practical range.

5.5.6 Dynamic compliance—measurement bandwidth

The synchrophasor measurement bandwidth shall be determined by sweeping the input with sinusoidal amplitude and phase modulation. This shall be done by modulating balanced three-phase input signals (voltages and currents) with sinusoidal signals applied to signal amplitudes and phase angles simultaneously in accordance with Table 5 and Table 6. Mathematically the input signals may be represented by Equation (15), Equation (16), and Equation (17):

$$X_a = X_m [1 + k_x \cos(\omega t)] \times \cos [\omega_0 t + k_a \cos(\omega t - \pi)] \quad (15)$$

$$X_b = X_m [1 + k_x \cos(\omega t)] \times \cos [\omega_0 t - 2\pi/3 + k_a \cos(\omega t - \pi)] \quad (16)$$

$$X_c = X_m [1 + k_x \cos(\omega t)] \times \cos [\omega_0 t + 2\pi/3 + k_a \cos(\omega t - \pi)] \quad (17)$$

where X_m is the amplitude of the input signal, ω_0 is the nominal power system frequency, ω is the modulation frequency in radians/s, $f_m = \omega/2\pi$ is the modulation frequency in Hz, k_x is the amplitude modulation factor, and k_a is the phase angle modulation factor.

The positive sequence signal corresponding to the above three-phase inputs is given by Equation (18):

$$X_1 = X_m [1 + k_x \cos(\omega t)] \times \cos [\omega_0 t + k_a \cos(\omega t - \pi)] \quad (18)$$

At reporting time tags $t = nT$ (where n is an integer and T is the phasor reporting interval) the PMU shall produce a positive sequence measurement of:

$$X(nT) = \{X_m/\sqrt{2}\}[1 + k_x \cos(\omega nT)] \angle \{k_a \cos(\omega nT - \pi)\} \quad (19)$$

within the error limits given in Table 5.

Frequency and ROCOF measurement performance shall also be determined during this test. For the input signals defined above and at reporting times $t = nT$, frequency, frequency deviation, and ROCOF are given respectively by Equation (20), Equation (21), and Equation (22):

$$f(nT) = \omega_0/2\pi - k_a (\omega/2\pi) \sin(\omega nT - \pi) \quad (20)$$

$$\Delta f(nT) = -k_a (\omega/2\pi) \sin(\omega nT - \pi) \quad (21)$$

$$\text{ROCOF}(nT) = d/dt[f(nT)] = -k_a (\omega^2/2\pi) \cos(\omega nT - \pi) \quad (22)$$

The modulation tests shall be performed with ω , k_x , and k_a over the frequency ranges specified in Table 5. The modulation frequency shall be varied in steps of 0.2 Hz or smaller over the range specified in the table. The TVE, FE, and RFE shall be measured over at least two full cycles of modulation. The maximum is the highest value observed at the given reporting rate over the full test interval. This maximum shall be within the specified limits for P class and M class compliance at the given reporting rate. An adequate settling time shall be allowed for each test signal change to prevent parameter change transient effects from distorting the measurement.

Table 5—Synchrophasor measurement bandwidth requirements using modulated test signals

Modulation level	Reference condition	Minimum range of influence quantity over which PMU shall be within given TVE limit			
		P class		M class	
		Range	Max TVE	Range	Max TVE
$k_x = 0.1$, $k_a = 0.1$ radian	100% rated signal magnitude, f_{nominal}	Modulation frequency 0.1 to lesser of $F_s/10$ or 2 Hz	3%	Modulation frequency 0.1 to lesser of $F_s/5$ or 5 Hz	3%
$k_x = 0$, $k_a = 0.1$ radian	100% rated signal magnitude, f_{nominal}		3%		3%

Table 6—Frequency and ROCOF performance requirements under modulation tests

Modulation level, reference condition, range (use the same modulation levels and ranges under the reference conditions specified in Table 5)	Error requirements for compliance			
	P class		M class	
	Max FE	Max RFE ^a	Max FE	Max RFE ^a
$F_s > 20$	0.06 Hz	3 Hz/s	0.3 Hz	30 Hz/s
$F_s \leq 20$	0.01 Hz	0.2 Hz/s	0.06 Hz	2 Hz/s

^a Frequency and ROCOF follow the modulated signal just as the phasor estimate does, and measure the combined effects of the fundamental signal and the modulation. The errors in both measurements are a small fraction of the measured values, but since ROCOF (the second derivative of phase) becomes a large value, the expected error is also large. Note from the given formulas that the magnitude of frequency deviation increases linearly with frequency, but ROCOF increases by frequency squared.

5.5.7 Dynamic compliance—performance during ramp of system frequency

Measurement performance during system frequency change shall be tested with linear ramp of the system frequency applied as balanced three-phase input signals (voltages and currents). Mathematically the input signals may be represented by Equation (23), Equation (24), and Equation (25):

$$X_a = X_m \cos [\omega_0 t + \pi R_f t^2] \quad (23)$$

$$X_b = X_m \cos [\omega_0 t - 2\pi/3 + \pi R_f t^2] \quad (24)$$

$$X_c = X_m \cos [\omega_0 t + 2\pi/3 + \pi R_f t^2] \quad (25)$$

where X_m is the amplitude of the input signal, ω_0 is the nominal power system frequency, and $R_f (= df/dt)$ is the frequency ramp rate in Hz/s (fixed value in this equation).

The positive sequence signal corresponding to the above three-phase inputs is given by Equation (26):

$$X_1 = X_m \cos [\omega_0 t + \pi R_f t^2] \quad (26)$$

At reporting time tags $t = nT$ (where n is an integer and T is the phasor reporting interval) the PMU shall produce a positive sequence measurement as shown in Equation (27):

$$X(nT) = \{X_m/\sqrt{2}\} \angle \{\pi R_f (nT)^2\} \quad (27)$$

During ramp tests, the true values of frequency, frequency deviation, and ROCOF for the specified test signals at reporting time tags $t = nT$ are given, respectively, by Equation (28), Equation (29), and Equation (30):

$$f(nT) = \omega_0/2\pi + (R_f)(nT) \quad (28)$$

$$\Delta f(nT) = (R_f)(nT) \quad (29)$$

$$d/dt[f(nT)] = R_f \quad (30)$$

The ramp rate and frequency range as well as the measurement error limits are shown in Table 7 and Table 8. Note that the allowed TVE, FE, and RFE may be exceeded during a “transition time” before and after a sudden change in ROCOF is made. The error calculation shall exclude measurements during the first two sample periods before and after a change in the test ROCOF. Sample periods are the reporting interval, $1/F_s$, of the given test. For example, if the reporting rate $F_s = 30$ fps, then measurements reported during a period of 67 ms before and after a transition shall be discarded. The test shall not include frequency discontinuities (frequency steps).

Table 7—Synchrophasor performance requirements under frequency ramp tests

Test signal	Reference condition	Minimum range of influence quantity over which PMU shall be within given TVE limit			
		Ramp rate (R_f) (positive and negative ramp)	Performance class	Ramp range	Max TVE
Linear frequency ramp	100% rated signal magnitude, & f_{nominal} at start or some point during the test	± 1.0 Hz/s	P class	± 2 Hz	1%
			M class	Lesser of $\pm (F_s/5)$ or ± 5 Hz ^a	1%

^a For $F_s = 12$ fps, ramp range shall be $\pm 2/3$ (two and one-third) Hz to allow for an integer number of samples in the result.

Table 8—Frequency and ROCOF performance requirements under frequency ramp tests

Signal specification	Reference condition	Transition time	Error requirements for compliance			
			P class		M class	
Ramp tests—same as specified in Table 7	100% rated signal magnitude and 0 radian base angle	$\pm 2/F_s$ for the start and end of ramp	Max FE	Max RFE	Max FE	Max RFE
			0.01 Hz	0.1 Hz/s	0.005 Hz	0.1 Hz/s

5.5.8 Dynamic compliance—performance under step changes in phase and magnitude

Performance during step changes in magnitude and phase shall be determined by applying balanced three-phase step changes to balanced three-phase input signals (voltages and currents). This test is mathematically represented in Equation (31), Equation (32), and Equation (33):

$$X_a = X_m [1 + k_x f_1(t)] \times \cos [\omega_0 t + k_a f_1(t)] \quad (31)$$

$$X_b = X_m [1 + k_x f_1(t)] \times \cos [\omega_0 t - 2\pi/3 + k_a f_1(t)] \quad (32)$$

$$X_c = X_m [1 + k_x f_1(t)] \times \cos [\omega_0 t + 2\pi/3 + k_a f_1(t)] \quad (33)$$

where X_m is the amplitude of the input signal, ω_0 is the nominal power system frequency, $f_1(t)$ is a unit step function, k_x is the magnitude step size and k_a phase step size. This test is a transition between two steady states used to determine response time, delay time, and overshoot in the measurement. Step functions with parameters as specified in Table 9 shall be applied and the measurements shall meet the requirements in Table 9 and Table 10. 0 illustrates the measurements.

Response time and delay time are defined in 5.3.3. The steady-state error limits from Table 3 and Table 4 shall be used for determining the response time. These limits are 1% TVE, 0.005 Hz FE, and 0.01 Hz/s RFE. The delay time is determined by the time when the stepped parameter achieves a value that is halfway between the starting and ending steady-state values. The times when error limits are crossed and the measurement crosses the 50% line shall be determined to an accuracy of one-tenth of the reporting rate that is being tested ($F_s/10$). Achievement of this accuracy shall be confirmed by test analysis.

NOTE—The PMU response times and delay times are small compared to the PMU reporting intervals. The specified response times (in Table 9 and Table 10) are less than three or five reporting intervals, and delay times are less than a quarter of a reporting interval. It is unlikely that reported data points will fall on the specified measurement points, so determining those points with a single step test may be insufficient. A series of tests with the step applied at varying times relative to the reporting times can be used to achieve this result.

This equivalent time sampling approach can achieve the required measurement resolution. In effect, this technique moves the step time to derive points on the measurement to “fill in” a curve. The PMU measurement reports are at fixed points in time relative to the UTC second, so moving the steps a fraction of the reporting interval gives reports at different points on the measurement curve. These measurements are combined to give a step response result with a time resolution less than the reporting interval. This technique controls the relation between the step time t in the unit step function $f_1(t)$ and one of the reporting times. The unit step function time is adjusted to fall on a reporting time for one step test. Successive step tests are performed with the unit step function times falling at increasing fractions of a reporting interval after a reporting time. Thus, if t_r is a general reporting time, T is the reporting interval, and n is the number of tests to be performed, one test is performed with a $f_1(t_r)$. The next test is performed with a $f_1(t_r + T/n)$, and the next with a $f_1(t_r + 2T/n)$, and so on until the n th test is performed with a $f_1(t_r + (n - 1)T/n)$. The resulting measurement points are interleaved by aligning all of the steps at the same point and combining the measurements with their corresponding offsets from the step. This gives an equivalent measurement step response with a time resolution of T/n . In general, an accurate measurement of the PMU response time, the delay time, and the overshoot percentage can be made with $n = 10$.

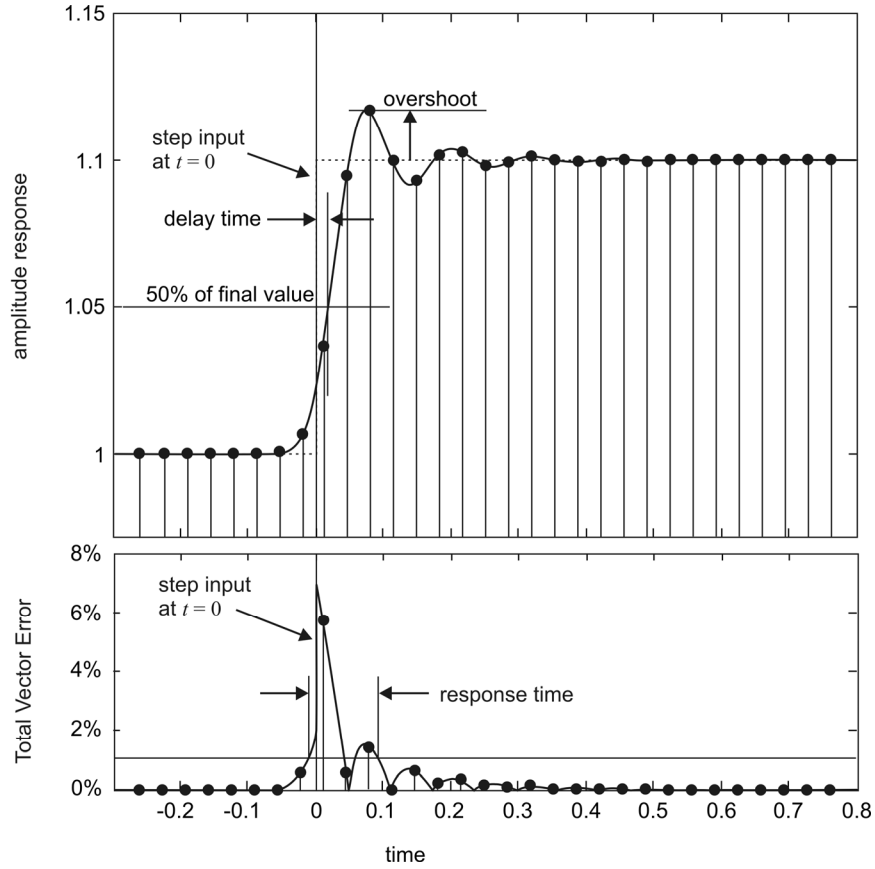

Reported values are represented by the dots on a vertical line. The continuous response line will be determined by the equivalent time sampling described above. This figure illustrates response time, delay time, and overshoot measurements. Response time is determined from the error measurement (here TVE, but FE and RFE are done similarly). Delay and overshoot are determined by the curve of the parameter being stepped. Note that maximum overshoot may be over or under the final value, and the delay time may be positive or negative.

Figure 4—Example of step change measurements using a magnitude step at $t = 0$

Table 9—Phasor performance requirements for input step change

Step change specification	Reference condition	Maximum response time, delay time, and overshoot					
		P class			M class		
		Response time (s)	Delay time (s)	Max overshoot/undershoot	Response time (s)	Delay time (s)	Max Overshoot/undershoot
Magnitude = $\pm 10\%$, $k_x = \pm 0.1$, $k_a = 0$	All test conditions nominal at start or end of step	$1.7/f_0$	$1/(4 \times F_s)$	5% of step magnitude	See Table 11	$1/(4 \times F_s)$	10% of step magnitude
Angle $\pm 10^\circ$, $k_x = 0$, $k_a = \pm \pi/18$	All test conditions nominal at start or end of step	$1.7/f_0$	$1/(4 \times F_s)$	5% of step magnitude	See Table 11	$1/(4 \times F_s)$	10% of step magnitude

Table 10—Frequency and ROCOF performance requirements for input step change

Signal specification	Reference condition	Maximum response time			
		P class		M class	
		Frequency response time (s)	ROCOF response time (s)	Frequency response time (s)	ROCOF response time (s)
Magnitude test as in Table 9	Same as in Table 9	$3.5/f_0$	$4/f_0$	See Table 11	See Table 11
Phase test as in Table 9	Same as in Table 9	$3.5/f_0$	$4/f_0$	See Table 11	See Table 11

Table 11—Response time for M class phasor, frequency, and ROCOF for input step change

Maximum response time in step change test for M class, in seconds										
Reporting rate (F_s)	10	12	15	20	25	30	50	60	100 ^a	120 ^a
Phasor (TVE)	0.595	0.493	0.394	0.282	0.231	0.182	0.199	0.079	0.050	0.035
Frequency (FE)	0.869	0.737	0.629	0.478	0.328	0.305	0.130	0.120	0.059	0.053
ROCOF (RFE)	1.038	0.863	0.691	0.520	0.369	0.314	0.134	0.129	0.061	0.056

^a Rates higher than 60 are not required, so this listing is advisory only. Rates even higher will be limited by the measurement window. Rates lower than 10/s are not expected to be used for dynamic measurement and are not included in this table.

5.5.9 Measurement reporting latency compliance

The latency in measurement reporting is a critical factor for measurements used in real-time applications, particularly controls. In addition to measurement latency there are many factors contributing to reporting delay, such as communication coding and transmission distance. The application using the data shall take into account *all* delays to determine system performance. As defined in 5.3.4, measurement latency includes not only the various computation delays, but the effect of where an event occurs relative to the

reporting time so that it will always be greater than one reporting period ($1/F_s$). These factors are included in this performance requirement.

PMU real-time output reporting latency shall be determined for each reporting rate F_s using at least 1000 consecutive messages. The reporting latency is the maximum of these values. The latency shall be determined to an accuracy of at least 0.0001 s. See Table 12.

Table 12—Measurement reporting latency

Performance class	Maximum measurement reporting latency (s)
P class	$2/F_s$
M class	$5/F_s$

Annex A

(informative)

Bibliography

Bibliographical references are resources that provide additional or helpful material but do not need to be understood or used to implement this standard. Reference to these resources is made for informational use only.

- [B1] Brigham, E. O., *The Fast Fourier Transform*. New York, Prentice Hall, 1974.
- [B2] *IEEE Standards Dictionary: Glossary of Terms & Definitions*.⁶
- [B3] IEEE Std 115TM-2009, IEEE Guide for Test Procedures for Synchronous Machines, Part I—Acceptance and Performance Testing; Part II—Test Procedures and Parameter Determination for Dynamic Analysis.^{7, 8}
- [B4] IEEE Std 1012TM-1998, IEEE Standard for Software Verification and Validation.
- [B5] IEEE Std 1344TM-1995, IEEE Standard for Synchrophasors for Power Systems.
- [B6] IEEE Std 1588TM-2008, IEEE Standard for a Precision Clock Synchronization Protocol for Networked Measurement and Control Systems.
- [B7] IEEE Std C37.111TM-1999, IEEE Standard Common Format for Transient Data Exchange (COMTRADE) for Power Systems.
- [B8] IEEE Std C37.118TM-2005, IEEE Standard for Synchrophasors for Power Systems.
- [B9] IEEE Std C37.118.2TM-2011, IEEE Standard for Synchrophasor Data Transfer for Power Systems.
- [B10] IEEE Std C37.238TM-2011, IEEE Standard Profile for Use of IEEE 1588TM Precision Time Protocol in Power System Applications.
- [B11] IEEE Std C57.13TM-2008, IEEE Standard Requirements for Instrument Transformers.
- [B12] Synchrophasor Measurement Standard, WAMS & Time Synchronization Working Group of SAC 82, China (PRC), 2010.
- [B13] Wicker, S. B., *Error Control Systems for Digital Communications and Storage*. Upper Saddle River, NJ: Prentice Hall, 1995.

⁶ The *IEEE Standards Dictionary: Glossary of Terms & Definitions* is available at <http://shop.ieee.org/>.

⁷ IEEE publications are available from the Institute of Electrical and Electronics Engineers, 445 Hoes Lane, Piscataway, NJ 08854, USA (<http://standards.ieee.org>).

⁸ The IEEE standards or products referred to in Annex A are trademarks owned by the Institute of Electrical and Electronics Engineers, Incorporated.

Annex B

(informative)

Time tagging and dynamic response

B.1 Dynamic response

As defined in 1.2, the primary purpose of this standard is to ensure PMU interoperability. IEEE Std C37.118-2005 [B8] introduced measurement compliance specifications for steady-state operation. This standard expands that context to dynamic response to transient conditions so all operational measurements shall be comparable. This annex discusses aspects of time tags and measurement errors.

Identical PMUs (defined as having identical hardware and algorithms) should yield the same phasor measurement under all conditions. However, two PMUs with different algorithms and/or different analog circuitry can be expected to yield somewhat different results for the same phasor measurement in transient state (the time during which a change in magnitude, phase angle, or frequency takes place). Test requirements and measurement evaluation in Clause 5 detail requirements to assure that measurements in both steady-state and transient conditions are comparable.

B.2 Time tags

Phasor measurements are the estimated phasor representation of a sinusoidal signal. The estimation is made for the signal at a particular instant of time, and that time is represented by the phasor time tag. The process of making a phasor estimate will require sampling the waveform over some interval of time that can lead to some confusion as to which time within that window is the correct time tag for the phasor.

In the original synchrophasor standard, IEEE Std 1344-1995 [B5], this was defined as the last sample in the window. While this yields a measurement that appears causal, it also yields ambiguity in response due to the length of the window. Further investigation also showed that this provides an undesirable phase angle measurement error with change in frequency.

Consequently in the succeeding standard, IEEE Std C37.118-2005 [B8], the time tag was defined as the time of the theoretical phasor that the estimated phasor represents. This acknowledges that the synchrophasor is actually an estimate of the sinusoid parameters over the window of observation rather than a response to the input. The estimate covers a short period of time, so will represent some kind of “average” of the parameters that may be changing during that window. In most cases the phasor estimate will be best represented by a time at the center of the estimation window. It is up to the designer to create a conversion process that assures that the magnitude and phase angle are properly represented, according to the TVE evaluation defined in 5.3.

If the power system frequency is different from its nominal value, the phasor will rotate as illustrated in Table 2 in 5.4.3. Although this represents a steady-state condition (as defined in 5.5.5), it is easy to show that the instantaneous value of the phasor phase angle will be determined by the choice of the time tag and the inherent group delay associated with the actual measurement algorithm. This behavior is illustrated in Figure B.2, where a step in frequency from f_0 to $f_0 + 5$ Hz is applied at $t = 0$. The curves illustrate the estimate produced by three different algorithms without group delay compensation.

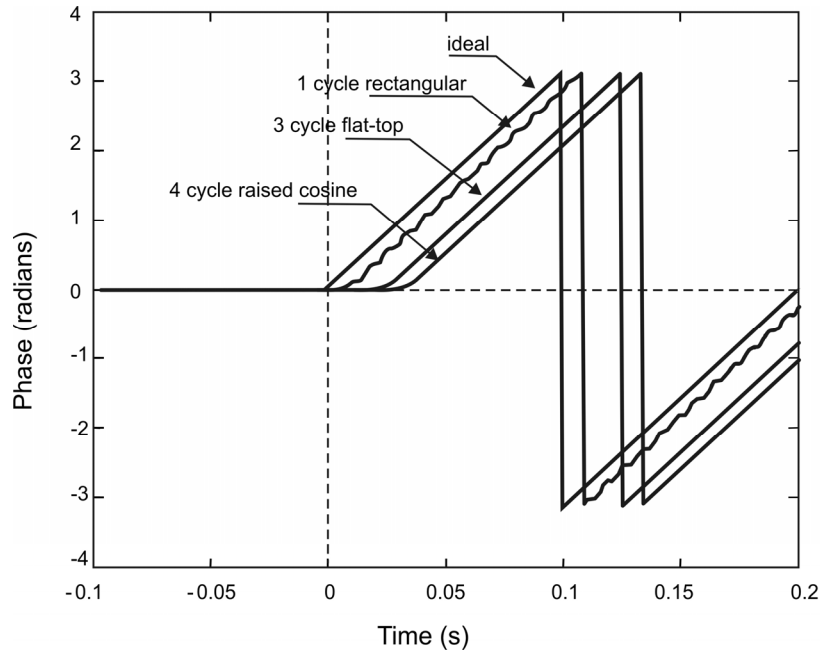

**Figure B.1—Frequency step test phase response without group delay compensation—
+5 Hz frequency step at $t = 0$**

By relying on the TVE concept defined in 5.3, this standard eliminates the off-nominal frequency phase angle ambiguity and ensures the compatibility between different PMUs. All compensation for group delay or other deficiencies of the estimation shall be compensated by the manufacturer. Figure B.2 shows multiple device output (from Figure B.1) after group delay compensation. In this figure, devices closely track each other, with four traces virtually indistinguishable from each other.

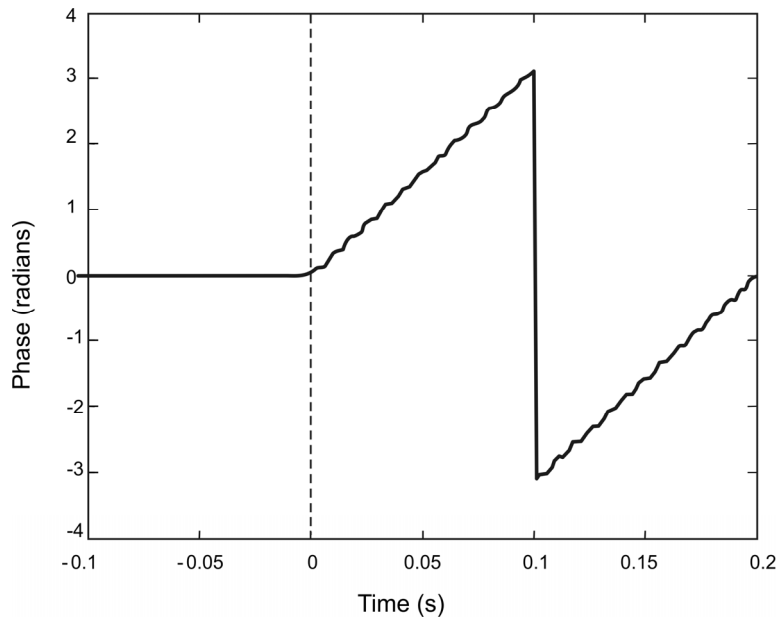

**Figure B.2—Frequency step test phase response after group delay compensation
(Ideal +3 algorithms, corresponding to Figure B.1)**

Figure B.3 shows the results of these same three algorithms with group delay compensation under a 10% negative step in magnitude. This shows there will be differences in responses even though the group delay is compensated. The differences are small and will be imperceptible under most data reporting rates since sample rates are much slower than what is illustrated here. The responses are centered at the step ($t = 0$), they meet the response time requirement for P class at 180 fps (and all lower reporting rates), and all overshoot requirements.

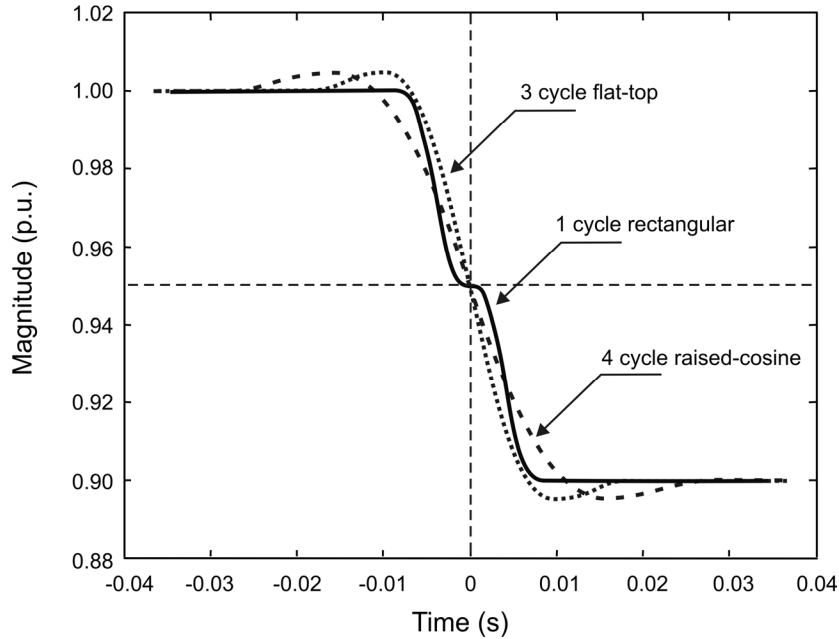

Figure B.3—Magnitude step test results for three different algorithms (group delay compensated, corresponding to Figure B.2)—per unit (PU) voltage or current is normalized to the reference (V/V_{ref} or I/I_{ref})

Group delay of a Finite Impulse Response (FIR) filter based algorithm with symmetric or anti-symmetric coefficients is equal to one-half of the window length (time tag in the center of the window). Infinite Impulse Response (IIR) filters, asymmetric FIR filters, and optimization-based algorithms may stretch the trailing edge, making the time response asymmetrical. Furthermore, as indicated in Figure B.3, the *transient* behavior will vary depending on the type of algorithm used for phasor estimation. Instead of mandating a single measurement algorithm, this standard defines the performance under a variety of conditions and the use of TVE as the primary tool for phasor measurement device performance assurance.

B.3 Magnitude step test example

Results of a simulated magnitude step test obtained with the P class algorithm presented in Annex C are illustrated in Figure B.4. TVE limits defined in 5.3 are indicated by thin horizontal lines. It is clear that under steady-state conditions, simulated PMU response stays within the prescribed TVE requirement. However, during the step the TVE significantly exceeds the steady-state requirement. For this reason, the performance requirements in 5.5.8 do not specify a maximum TVE during a specified time period before and after the step time for both the P class and M class devices.

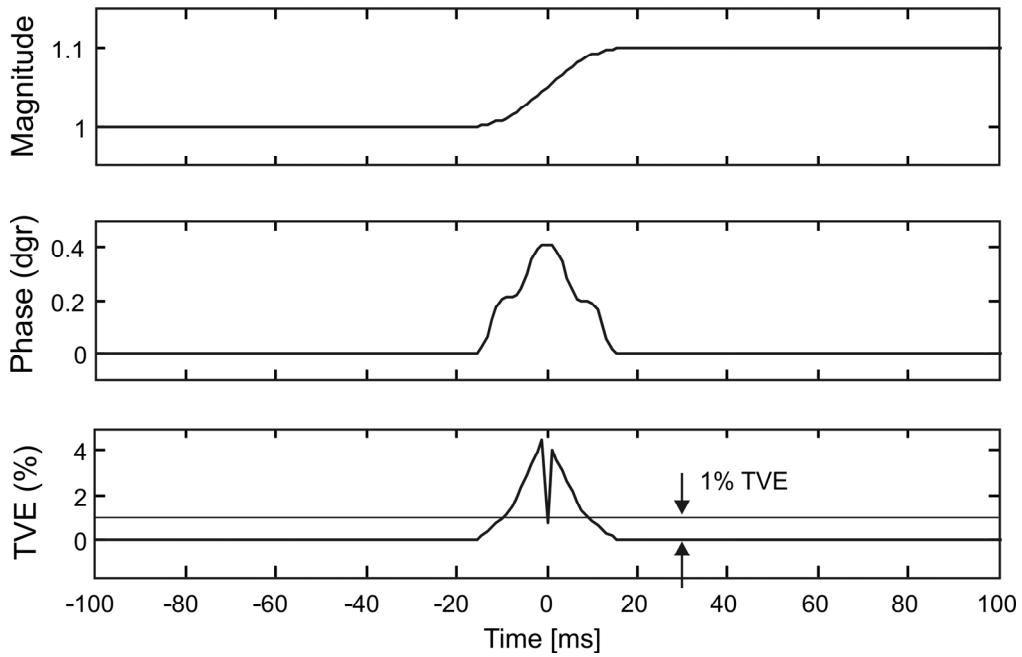

Figure B.4—Magnitude step test example (10% step, P class algorithm)

Annex C

(informative)

Reference signal processing models

C.1 Introduction

This annex presents the reference signal processing models used to develop and verify performance requirements in this standard. It is given for information purposes only, and does not imply being the only (or recommended) method for estimating synchrophasors. Its purpose is to establish common ground for understanding performance requirements and confirming their achievability.

Subclause C.2 includes a reference model for the general synchrophasor derivation. This model is the same for both algorithms presented in this subclause.

Subclause C.3 has the specific model and formulas for P class verification. This is a simple derivation based on a fixed frequency two-cycle estimator designed to remove the second (and higher) harmonics in order to meet frequency deviation requirements. The P class filter length is constant for all output rates, meaning that PMU output generated at lower rates (<50 msg/s or 60 msg/s) may contain additional aliasing components.

Subclause C.4 has the specific model and related equations for the M class verification. This model uses a low-pass filter for 20 dB of out-of-band rejection in all signals.

C.2 Basic synchrophasor estimation model

Figure C.1 shows typical processing steps performed within the PMU. It assumes fixed frequency sampling synchronized to an absolute time reference, followed by complex multiplication with the nominal frequency carrier. Other implementations using frequency tracked sampling, frequency tracked carrier, or nonlinear estimation methods are also possible and are permitted by the standard. Depending on the algorithm and windowing, the output from this conversion may be at the original sample rate or lower.

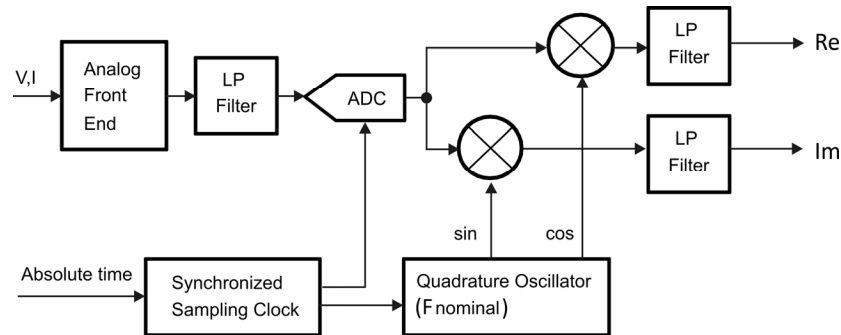

Figure C.1—Single phase section of the PMU phasor signal processing model

Given a set of samples of a single phase of the power signal $\{x_i\}$, the synchrophasor estimate $X(i)$ at the i th sample time is:

$$X(i) = \frac{\sqrt{2}}{\text{Gain}} \times \sum_{k=-N/2}^{N/2} x_{(i+k)} \times W_{(k)} \times \exp(-j(i+k)\Delta t\omega_0) \quad (\text{C.1})$$

$$\text{Gain} = \sum_{k=-N/2}^{N/2} W_{(k)} \quad (\text{C.2})$$

where

- ω_0 = $2\pi f_0$ where f_0 is the nominal power system frequency (50 Hz or 60 Hz)
- N = FIR filter order (number of filter taps is equal to $N + 1$)
- Δt = 1/sampling frequency
- x_i = sample of the waveform at time $t = i \Delta t$, where the time $t = 0$ coincides with a 1 s rollover
- $W_{(k)}$ = low-pass filter coefficients (depending on P or M class filtering)

Equation (C.1) represents the complex demodulation and low-pass filtering shown in Figure C.1. Note that $\exp(-j(i+k)\Delta t\omega_0)$ is Euler's equation and includes multiplication of the input by the quadrature oscillator (sine and cosine) shown in Figure C.1. The low-pass filtering ($W_{(k)}$) can be applied individually to the *real* and *imaginary* outputs of the complex demodulator as shown in Figure C.1.

C.3 Time-stamp compensation for low-pass filter group delay

The time-stamp of the PMU output represents the phasor equivalent, frequency, and ROCOF of the power system signal at the time it is applied to the PMU input. All of these estimates must be compensated for PMU processing delays including analog input filtering, sampling, and estimation group delay. If the sample time tags are compensated for all input delays, the time tag of the sample in the middle of the estimation window can be used for the phasor estimation (output) time tag as long as the filtering coefficients are symmetrical across the filtering window. This method of group delay compensation is used with both the P class and the M class algorithms presented in this annex.

The filter coefficients for P class and M class low-pass filters are derived in C.5 and C.6, respectively. Filter order for FIR filters is determined by the number of elements in the filter; the order is one less than the number of elements (taps) of the filter. For example, a 1 cycle Fourier filter using 15 samples/cycle is an $N = 15 - 1 = 14$ th order filter. Examples provided in this annex use even order filters (odd number of taps). Resulting filter group delay is an integer multiple of the sampling frequency: $Gd = N/2 \times \Delta t$.

C.4 Positive sequence, frequency, and ROCOF

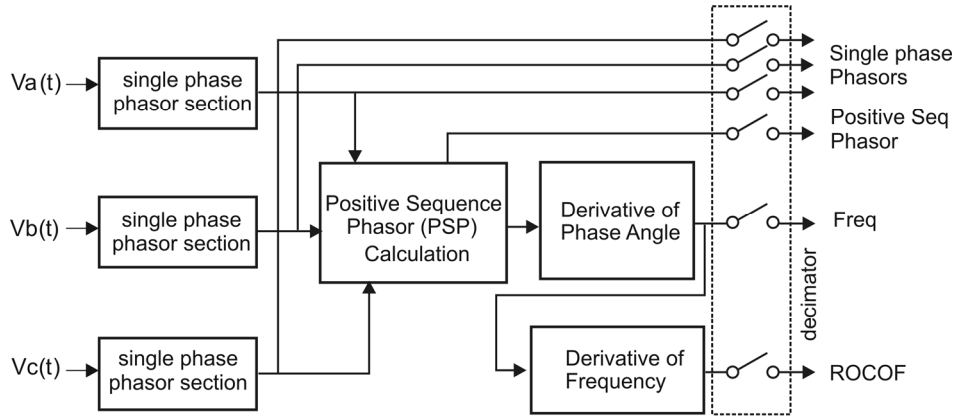

Figure C.2—Complete PMU signal processing model—all processing shown is at the A/D sampling rate; reporting rate is produced by resampling at the system output (decimator stage)

The normal positive sequence is calculated using the symmetrical component transformation. Frequency is then calculated from the rate of change of phase angle. Since phase angle changes relative to the difference between the actual frequency and the nominal frequency, this approach yields the offset from nominal. This algorithm uses differences among the four most recent angles weighted strongly to the last two angle differences. It is set up this way to smooth out the estimate, particularly for the case of limited resolution as would be found in a real PMU. For this modeling, there was little difference in the performance of this algorithm and a frequency estimate derived from the angle difference between the two most recent angles. The frequency estimation algorithm is shown in Equation (C.3):

$$\Delta F(i) = \{6[\theta(i) - \theta(i-1)] + 3[\theta(i-1) - \theta(i-2)] + [\theta(i-2) - \theta(i-3)]\} / [20\pi \times \Delta t] \quad (C.3)$$

where $\theta(i)$ is the angle of the i th positive sequence estimate $X(i)$, $\theta(i-1)$ is the angle of the previous estimate, etc. The ROCOF estimate is then computed as the rate of change of the frequency estimate shown in Equation (C.4):

$$DF(i) = [\Delta F(i) - \Delta F(i-1)] / \Delta t \quad (C.4)$$

Due to using angles behind (older than) the current phasor estimate, the frequency estimate lags the phasor. The frequency estimate could be exactly aligned with the phasor by waiting for the next phasor estimate and then computing frequency using one angle ahead and one angle behind the current phasor. This requires delaying the output of the phasor value while waiting for the next phasor. The delay is only one sample period (Δt), which is small; however the differences caused by the delay using the given method are small also. The point here is that values computed using the given formula easily pass the requirements, and many other methods such as second order fit or weighted least squares will also, but all methods will require trade-offs, which are discussed in C.6. Note that simple finite difference equations like these are also very sensitive to noise.

C.5 P class reference model for phasor and frequency derivation

The P class phasor estimation algorithm presented here uses fixed length two-cycle triangular weighted FIR filter that is not changed for different PMU reporting rates. In order to simplify time stamp generation and phase compensation, the algorithm uses an odd number of samples (filter taps). This allows conversions and filtering to use a sample time stamp at the center of the window without adjustment. This reference algorithm implementation uses a sample rate of 15 samples/cycle, which becomes $60 \times 15 = 900$ samples/s for a 60 Hz system or $50 \times 15 = 750$ samples/s for a 50 Hz system. This algorithm can be implemented using a two-cycle FIR filter with triangular window coefficients shown in Figure C.3 [with filter order N being equal to $N = 2 \times (15 - 1) = 28$] or in two stages with a one-cycle Fourier conversion followed by uniform averaging over one cycle (cascaded boxcar filter approach). As long as the sample times are compensated for input delays, the time stamp at the center of the window produces an estimate whose phase follows the actual power system frequency and does not need further phase or delay correction. It does require magnitude correction for off-nominal frequency that is applied to the final phasor based on the frequency estimate. The complete process is diagrammed in Figure C.2.

C.5.1 P class filter details

The P class filter coefficients $W_{(k)}$ are defined as shown in Equation (C.5):

$$W_{(k)} = \left(1 - \frac{2}{N+2}|k|\right) \quad (\text{C.5})$$

where

$$k = -N/2 : N/2 \text{ (integer values only)}$$

$$N = \text{filter order } [N = (15 - 1) \times 2 = 28 \text{ for sampling frequency example with 15 samples per cycle}]$$

Example filter coefficients are shown in Figure C.3.

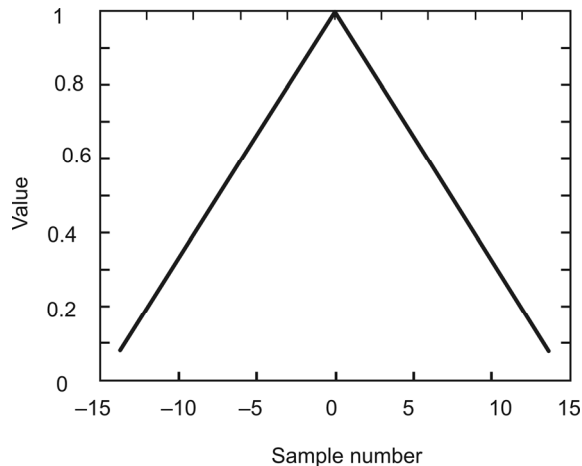

Figure C.3—P class filter coefficient example [$N = 2 \times (15 - 1) = 28$]

The P class filter works well at the nominal frequency for all but out-of-band rejection. For off-nominal frequency, the period of estimation does not match the actual period of the signal. Phase estimation works well because the signal is centered on the estimate. However, the estimate magnitude rolls off and needs compensation. The harmonic rejection is excellent when the conversion matches the system frequency.

When it does not, such as under off-nominal frequency, harmonics are not suppressed very well, which causes some problems with frequency and ROCOF estimation.

When PMU implementation is made with a fixed conversion frequency f_0 , the phasor magnitude will roll off as the signal frequency deviates from f_0 . The result is a $(\sin(x)/x)^2$ curve determined by the two-cycle low-pass filter response shown in Figure C.4.

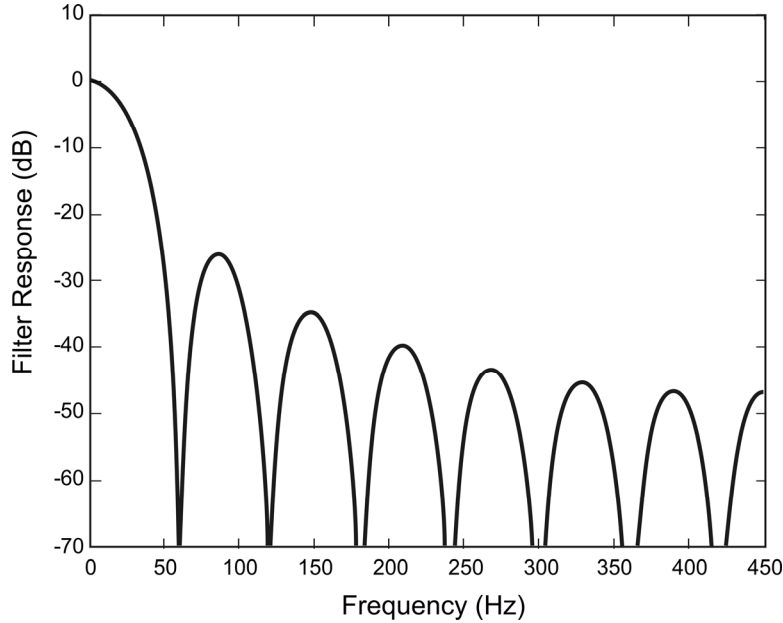

Figure C.4—P class filter response as a function of frequency
[example shows: $f_0 = 60$ Hz, $f_{\text{sampling}} = 15 \times 60 = 900$ Hz, $N = 2 \times (15 - 1) = 28$]

Over a limited frequency range, this deviation can be compensated by dividing the phasor magnitude by the P class filter response at the measured frequency. With this algorithm, the phase angle measurement is accurately computed at all frequencies using the estimate centered in the window. The magnitude is compensated by dividing the magnitude with a sine at the actual signals frequency. The two-cycle triangular window produces a faster rolloff than a standard one-cycle rectangular window, so the frequency deviation is spread with an additional factor of 1.625 to increase compensation (the factor was derived experimentally) as shown in Equation (C.6):

$$\hat{X}(i) = X(i) / [\sin(\pi(f_0 + 1.625\Delta F(i)) / 2f_0)] \quad (\text{C.6})$$

where

$\Delta F(i)$ = deviation of frequency from nominal computed at point i as shown in Equation (C.3)

Equation (C.6), Equation (C.3), and Equation (C.4) are used for synchrophasor, frequency, and ROCOF estimation, respectively, in the P class model.

C.6 M class reference model for phasor and frequency derivation

The principal difference between P class and M class is that the M class has a requirement for filtering to attenuate by at least 20 dB signals that are above the Nyquist frequency for the given reporting rate. This filtering will result in longer reporting delays but will also reduce the likelihood of aliasing. Because of the

required filtering, the M class can produce somewhat higher accuracy, a fact that is reflected in the requirements.

The M class requirements for passband and stopband filtering are shown in Figure C.5. The figure is based on the M class requirements given in Table 3 and Table 5 in Clause 5, with corner frequency specifications linked to the PMU reporting rate. This mask is used as the mask for designing the reference filter. An FIR filter implementation was used to achieve linear phase response. The reference filter coefficients were obtained by using well-known “brick wall” filter design methodology based on “sinc” function $\frac{\sin(x)}{x}$ multiplied with a Hamming window. The filter order (length) is adjusted to meet frequency response requirements. This model assumes correct implementation of the front end scaling, anti-aliasing filter, A/D converter and adequate sampling rate that was set to 960 Hz in this example.

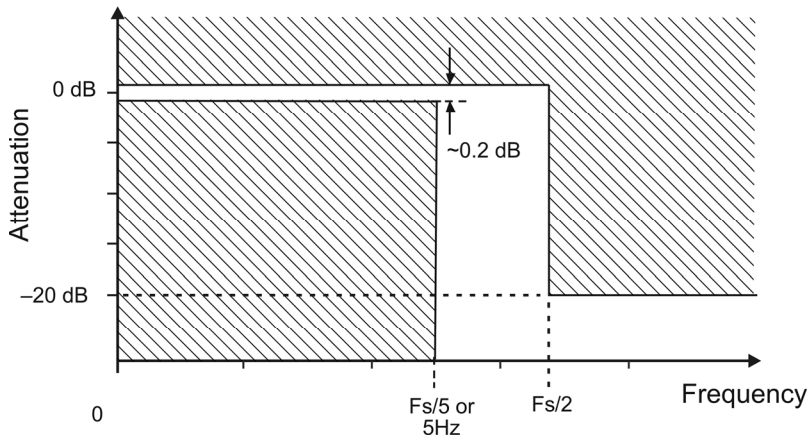

Figure C.5—Reference algorithm filter frequency response mask specification for M class (frequency response curve within unshaded region)

For Figure C.5, the filter response shall remain outside the shaded areas.

Equation (C.7) calculates a vector of filter coefficients:

$$W(k) = \frac{\sin\left(2\pi \times \frac{2F_{fr}}{F_{sampling}} \times k\right)}{2\pi \times \frac{2F_{fr}}{F_{sampling}} \times k} h(k) \quad (C.7)$$

where

- k = $-N/2 : N/2$
- N = filter order from Table C.1
- F_{fr} = low-pass filter reference frequency from Table C.1
- $F_{sampling}$ = sampling frequency of the system (960 samples/second for the reference model)
- $h(k)$ = Hamming function
- $W(0)$ = 1 (note when $k = 0$, $W = 0/0$, which is “not a number” and must be replaced by 1)

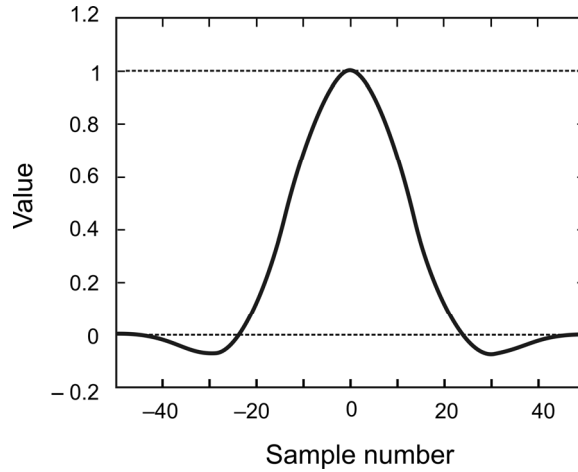

Figure C.6—M class filter coefficient example ($F_s = 60$ fps, $F_{\text{sampling}} = 960$ Hz, $N = 96$)

Table C.1 shows input parameters to generate the filter coefficients used to verify limits in this specification. It is given for information purposes only, and does not imply being the only (or recommended) filter:

Table C.1—M class low-pass filter parameters (example)

Reporting rate F_s		Filter reference frequency F_{fr} (Hz)	Filter order N
50 Hz	10	1.920	700
	25	4.800	280
	50	8.850	100
	100	16.000	44
60 Hz	10	1.920	794
	12	2.304	660
	15	2.880	528
	20	3.840	396
	30	5.616	238
	60	10.320	96
	120	18.960	40

C.7 Data rate reduction model

The reference model shown in Figure C.1 and Figure C.2 can be used to directly produce any of the output rates shown in Table C.1. If the PMU produces phasors, frequency, and ROCOF internally at a high rate and reduces the data stream for output, similar filters can be used to perform further decimation (derive lower rates) for M class outputs as shown in Figure C.7. This method can be used when multiple rate outputs are required from the same PMU and in the case of a phasor data concentrator (PDC) application. It is important to note that the out-of-band rejection requirements specified in this standard for M class apply equally to lower frequency (decimated) synchrophasor data streams produced by both PMUs and PDCs. Consequently, decimated output data (lower rates) generated by the PDC are expected to remain comparable (have the same dynamic behavior) as those generated by the PMU. These same methods can be

used for P class, but the additional filtering is not required. P class data reduction can be accomplished by a simple $1/N$ resampling (i.e., taking every N th sample).

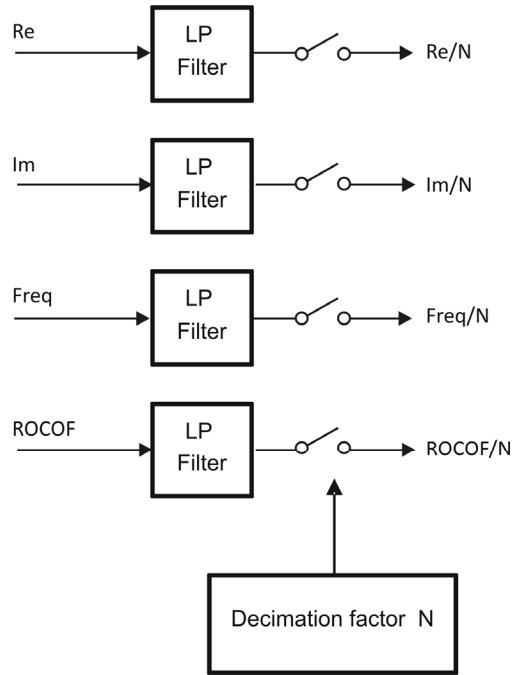

Figure C.7—Data rate reduction signal processing model

C.8 Tradeoffs in the reference model

C.8.1 Immunity to off-nominal components, reporting latency, and time alignment

Designers and users of PMUs need to consider three interrelated factors affecting the estimation of phasors, frequency, and ROCOF. The three factors, shown in Figure C.8, are as follows:

- Immunity to noise such as harmonics, interharmonics (out-of-band interfering signals), or modulations on the input signal
- Alignment of the frequency and ROCOF estimation to the time stamp of the phasor estimation
- Reporting latency (the time for the estimations to be completed and ready to transmit from the PMU)

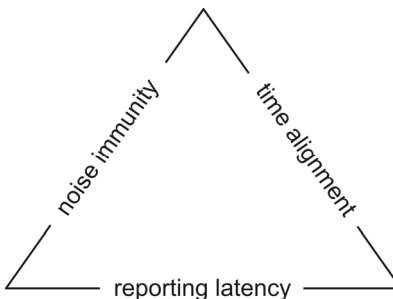

Figure C.8—Factors affecting estimation

The PMU reference model was designed to have relatively short reporting latency and good time alignment between the phasor, frequency, and ROCOF estimates. Good alignment and short latency comes at the cost of some immunity, as illustrated in Figure C.8. This model is meant to verify PMU performance limits, be relatively simple to understand and implement, and leave margin for actual PMUs. It is not intended to illustrate the ideal solution.

C.8.2 Response time and the accuracy of synchrophasors, frequency, and ROCOF measurements

The accuracy of the synchrophasors, frequency, and ROCOF measurements, when non-fundamental components are present in the signals, is directly affected by the reference filter gain and frequency response. In particular, the frequency components beyond the Nyquist frequency (half the value of the applied reporting rate) should be attenuated.

Figure C.9 exhibits the gain/frequency response of the reference filter with a reporting rate $F_s = 60$ fps and a data acquisition sampling frequency of 960 Hz. The attenuation level beyond the Nyquist frequency of 30 Hz is greater than 20 db.

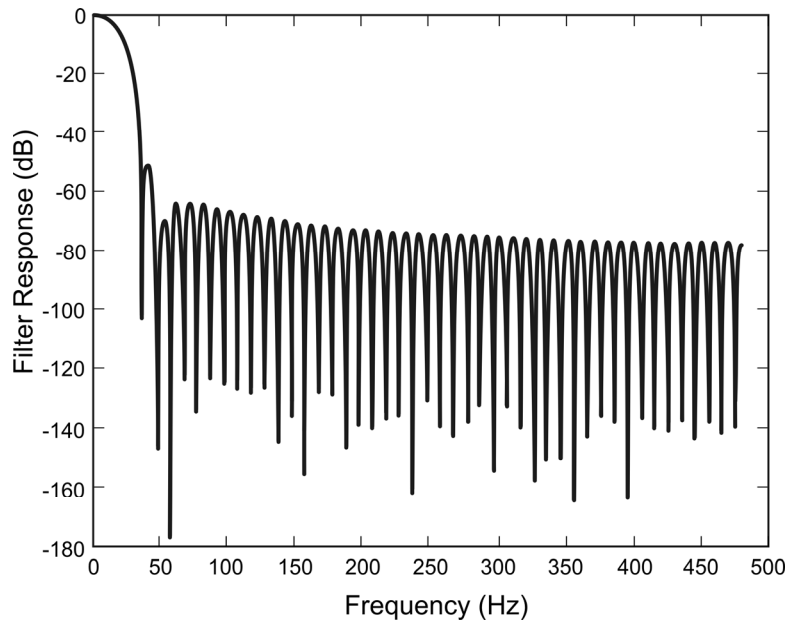

Figure C.9—Reference filter magnitude frequency response with $F_s = 60$ fps

Let us assume as an example that the voltage signals are at fundamental frequency with some added second harmonic component. After the demodulation has taken place when applying the reference algorithm, the second harmonic component will translate into two frequency components at 60 Hz and 180 Hz that are above the Nyquist frequency. The impact of the second harmonic on the synchrophasors, frequency, and ROCOF measurements accuracy depends on the attenuation provided by the reference filter at these two specific components: the higher the attenuation, the better the measurement accuracy. The same rationale could be applied to any non-fundamental component.

The model reference filter has been designed so that it allows a fast response time (65 ms for a 10% magnitude change at $F_s = 60$ fps) together with a good accuracy for the synchrophasor measurement. Better accuracy figures could be obtained for the frequency and ROCOF measurements by increasing the attenuation level beyond the Nyquist frequency, but that would be done at the expense of the synchrophasor measurement response time, which would become slower.

Annex D

(informative)

Time and synchronization communication

D.1 PMU time input

A PMU requires a source of UTC time synchronization. This may be supplied directly from a time broadcast such as GPS or from a local clock using a standard time code. IRIG-B is commonly used for local time dissemination. It may be provided in a level shift, a 1 kHz amplitude modulated signal, or in the bi-phase Manchester modulated format (modulation type 2, B2xx). If the amplitude modulation is used it may need to be supplemented with a 1 PPS pulse train to achieve the required accuracy. The IRIG-B amplitude modulated format is commonly available and hence is the most readily implemented. The newer Manchester format is more compatible with fiber optic and digital systems and provides complete synchronization without additional signals. Other forms of precise time distribution, such as standard Ethernet using IEEE Std 1588-2008 [B6], are emerging and will become increasingly available with new technology developments.

1 PPS. A common feature of timing systems is a pulse train of positive pulses at a rate of one pulse per second (1 PPS). The rising edge of the pulses coincides with the seconds change in the clock and provides a very precise time reference. The pulse widths vary from 5 μ s to 0.5 s, and the signal is usually a 5.0 V magnitude driving a 50 ohm load. A 1 PPS timing signal must be used with another system such as a serial timing message or IRIG-B to supply the full time synchronization.

IEEE 1588. IEEE Std 1588-2008 [B6] allows timing accuracies better than 1 μ s for devices connected via a network such as Ethernet. IEEE Std C37.238-2011 [B10] specifies a subset of IEEE 1588 functionality to be supported for power system protection, control, automation, and data communication applications utilizing an Ethernet communication architecture. At the time of this writing (2011) several commercially available Ethernet switches, grandmaster clocks, and slave clocks have implemented the IEEE C37.238 functionality and demonstrated this performance. Both standards may be obtained through the IEEE-SA web site.

IRIG-B. IRIG-B is fully described in IRIG Standard 200-04 published by the Range Commanders Council of the U. S. Army White Sands Missile Range. Time is provided once per second in seconds through day of year in a binary coded decimal (BCD) format and an optional binary second-of-day count. The standard allows a number of configurations that are designated as Bxyz where x indicates the modulation technique, y indicates the counts included in the message, and z indicates the interval. The most commonly used form is B122, which has seconds through day-of-year coded in BCD and is amplitude modulated on a 1 kHz carrier. The amplitude should be a peak-to-peak amplitude of 1 V to 6 V for the mark (peak) with a mark-to-space amplitude ratio 10:3 as provided in the standard. A block of 27 control bits is available for user assignment and can be used to supplement the standard code for continuous timekeeping. The time code format is:

<sync> SS:MM:HH:DDD <control> <binary seconds>

where

<sync> = the on-time sync marker
SS = the second of the minute [00 to 59 (60 during leap seconds)]
MM = the minute of the hour (00 to 59)
HH = the hour of day in 24 format (00 to 23)
DDD = the day of year (001 to 366)

<control> = a block of 27 binary control characters
<binary seconds> = a 17 bit second of day in binary

D.2 IRIG-B time code extensions

IRIG-B includes 27 control bits for user provided information in addition to the specified time codes. This subclause details assignments for these control bits that enable coding the year of century, non-sequential changes (leap seconds and daylight savings time), local time offsets, and time quality into the message. These assignments extend IRIG-B to a complete time message as needed by the utility industry. These extensions were first introduced with the IEEE synchrophasor standard, IEEE Std 1344-1995 [B5]. They were included in the succeeding standard, IEEE Std C37.118-2005 [B8], with a change in the sign of the local time offset. They are again carried forward to this standard with an added continuous time quality code.

Table D.1—Control bit assignments

IRIG-B Pos ID	CTRLBIT#	Designation	Explanation
P 50	1	Year, BCD 1	Last 2 digits of year in BCD.
P 51	2	Year, BCD 2	IBID
P 52	3	Year, BCD 4	IBID
P 53	4	Year, BCD 8	IBID
P 54	5	Not Used	Unassigned
P 55	6	Year, BCD 10	Last 2 digits of year in BCD.
P 56	7	Year, BCD 20	IBID
P 57	8	Year, BCD 40	IBID
P 58	9	Year, BCD 80	IBID
P 59	—	P6	Position identifier # 6
P 60	10	Leap Second Pending (LSP)	Becomes 1 s up to 59 s BEFORE leap second insert
P 61	11	Leap Second (LS)	0 = Add leap second, 1 = Delete leap second
P 62	12	Daylight Saving Pending (DSP)	Becomes 1 s up to 59 s BEFORE DST change
P 63	13	Daylight Savings Time (DST)	Becomes 1 s during Daylight Savings Time (DST)
P 64	14	Time Offset sign	Time offset sign—0 = +, 1 = -.
P 65	15	Time Offset—binary 1	Offset from coded IRIG-B time to UTC time.
P 66	16	Time Offset—binary 2	IRIG coded time minus time offset (including sign) equals UTC time at all times (offset will change during daylight savings).
P 67	17	Time Offset—binary 4	
P 68	18	Time Offset—binary 8	
P 69	—	P7	Position identifier # 7
P 70	19	Time Offset—0.5 h	0 = none, 1 = additional 0.5 h time offset
P 71	20	Time Quality—binary 1	4-bit code representing approx. clock time error. 0000 = clock locked to a traceable UTC source 1111 = clock failed, data unreliable Use Table D.2.
P 72	21	Time Quality—binary 2	
P 73	22	Time Quality—binary 4	
P 74	23	Time Quality—binary 8	
P 75	24	PARITY	Parity on <i>all preceding data</i> bits.
P 76	25	Continuous Time Quality—binary 1	3-bit code representing the estimated maximum time error in the transmitted message. This CTQ indicates error at all times. Use Table D.3.
P 77	26	Continuous Time Quality—binary 2	
P 78	27	Continuous Time Quality—binary 4	
P79	—	P8	Position identifier # 8

NOTE—The interpretation of the UTC offset encoded in control bits 14–19 changed between IEEE 1344-1995 [B5] and IEEE Std C37.118-2005 [B8]. In IEEE 1344-1995 the offset defined in those control bits was added to the IRIG time to get UTC time. In IEEE Std C37.118-2005 this was changed to subtracting the offset so the listed offset sign would be consistent with standard practice. In standard practice, time zones to the east of the Greenwich Meridian are positive and those to the west are negative. This standard retains the IEEE C37.118 method—the listed offset must be subtracted from IRIG to determine UTC time.

Virtually every timekeeping system is run by some kind of processor. Since IRIG time code numbers arrive *after* the on-time mark, the timekeeping system must generate the time tag based on the anticipated number rather than on what it just received. Consequently, time counts that are not in exact sequence require advance notice. Non-sequence clock counts include leap year, leap second, and daylight savings time changes. The leap second and daylight savings change bits warn of impending special clock counts, and the last two digits of the year alert the timing system of leap year changes.

As an interpretation of the IRIG standard, BCD time and straight binary seconds (SBS) shall be consistent. If BCD time changes by an hour for a daylight time change, SBS shall change at the same time to reflect a consistent count. The year will roll over with BCD time regardless of whether it corresponds with UTC time.

Year: The last two digits of the year is in straight BCD in the same format as the rest of the IRIG-B code and follows first after day of year. It will roll over with the day of year in the BCD time count.

Leap second: The leap second pending (LSP) and polarity (LS) bits show that one is about to happen and whether it will be inserted or deleted. Leap seconds have only been positive for the last 20 years, so LS = 0 is almost certain. The LSP bit shall be asserted between 1 s and 60 s before the hour it is to be inserted. The bit shall go to 0 when the second count goes to 00. Leap seconds are always inserted at UTC midnight by altering the second time count only. Thus in UTC time, the time count goes from 23:59:59 to 23:59:60 to 00:00:00 to add the extra second. In another time zone, say Pacific Standard Time, which is 8 h behind UTC, the same count will be 15:59:59 to 15:59:60 to 16:00:00. SBS shall give the count 57 600 (=16:00:00) twice.

Daylight savings: The Daylight Savings Pending (DSP) and Daylight Savings Time (DST) bits indicate that a change is about to happen and whether daylight savings is in effect. If DST = 0, then the impending change will be to ON, which will delete 1 h from the time scale (leap forward 1 h in the spring) and the Daylight Savings bit will go to one. If DST = 1, the opposite will occur. Daylight time changes will be 1 h and are asserted at the minute rollover. The DSP bit shall be asserted between 1 s and 60 s before time is to be changed. The DSP and DST bits shall change at the same time between the 59 s and 00 s counts. In the United States where the time change is put into effect at 2:00 AM, the time count in the Spring is 01:59:59 to 03:00:00. In the Fall, the count is 01:59:59 to 01:00:00.

Local time offset: The local time offset is a 5-bit binary count with a sign bit. The last bit is a fractional half-hour, which is used by a few countries. The offset gives the hours difference (up to ± 15.5 h) between UTC time and the IRIG-B time (both BCD and SBS codes). Subtracting the offset from the IRIG-B time using the included sign gives UTC time [e.g., if the IRIG-B time is 109:14:43:27 and the offset is -06 given by the code 0110.0 (Central Standard Time in North America), then UTC time is 109:20:43:27.] The local time offset shall always give the true difference between IRIG code and UTC time, so the offset changes whenever a daylight savings time change is made. This follows the standard convention of positive time offsets east of the GMT meridian and negative offsets west of the meridian.

Time quality (TQ): A 4-bit TQ indicator code is used by several manufacturers and is in several existing standards. It is an indicator of time accuracy or synchronization relative to UTC and is based on the clock's internal parameters. The code recommended here is by order of magnitude relative to 1 ns. It is basically the same as used in the HaveQuick and STANAG 4430 (NATO) time codes but with a more practical scale. The 1 ns basic reference is fine enough to accommodate all present industry uses now and into the foreseeable future. When locked to a UTC traceable source (such as GPS), all 4 bits of the TQ code shall be cleared to 0. All 4 bits shall be set to 1 during a clock failure and at startup before achieving a stable locked condition. Note that this flag cannot provide a time quality indication while the clock is locked to a UTC traceable source since all bits will be set to 0.

Table D.2—Four-bit Time Quality indicator code

Binary	Hex	Value (worst-case accuracy)
1111	F	Fault—clock failure, time not reliable
1011	B	Time within 10 s of UTC
1010	A	Time within 1 s of UTC
1001	9	Time within 10^{-1} s of UTC
1000	8	Time within 10^{-2} s of UTC
0111	7	Time within 10^{-3} s of UTC
0110	6	Time within 10^{-4} s of UTC
0101	5	Time within 10^{-5} s of UTC
0100	4	Time within 10^{-6} s of UTC
0011	3	Time within 10^{-7} s of UTC
0010	2	Time within 10^{-8} s of UTC
0001	1	Time within 10^{-9} s of UTC
0000	0	Clock is locked to a UTC traceable source

Parity: This parity covers all the preceding bits in the message from BCD seconds (P1) through time quality in the control bits (P74). SBS and P76–79 are not included. The value is equal to the modulo-2 addition of all the preceding bits (P1 through P74) in the message. The total number of 1's in the message (P1 through P75) is thereby made an even number. This results in EVEN parity.

Continuous time quality (CTQ): This CTQ is a 3-bit Time Quality indicator code that is provided in addition to the TQ given above. This additional code is active at all times, during both locked and unlocked conditions. It uses control bits 25, 26, and 27, which were unused in the previous version of this profile. These bits were previously set to 0 by default when this profile was implemented. These bits will never be all zero in this version of the profile, so an all zero code indicates implementation of the previous version of the profile. A time code receiver using CTQ can therefore identify if there is a valid CTQ present or not. Similarly, a time code receiver using the previous profile does not look at these bits, so the presence of a new code will not interfere with its operation. Since there are only seven codes available, they were chosen to best fit power system applications.

Table D.3—Three-bit Time Quality indicator code

Binary	Hex	Value (worst-case accuracy)
111	7	Estimated maximum time error > 10 ms or time error unknown
110	6	Estimated maximum time error < 10 ms
101	5	Estimated maximum time error < 1 ms
100	4	Estimated maximum time error < 100 μ s
011	3	Estimated maximum time error < 10 μ s
010	2	Estimated maximum time error < 1 μ s
001	1	Estimated maximum time error < 100 ns
000	0	Not used (indicates code from previous version of profile)

D.3 IRIG-B high-precision time code format

IRIG-B format transmitted using modified Manchester modulation is recommended as an alternative to the AM modulated IRIG-B with separate 1 PPS sync. This modulation is better adapted for both fiber and metallic digital systems. With the previous control bit assignments, this time code format can serve all power industry requirements now and in the foreseeable future.

Manchester coding provides a zero mean code that is easy to decode, even at low signal levels. The 1 kHz clock provides a precise on-time mark that is always present. The coding method mimics 1 kHz modulated IRIG-B with binary 1's and 0's in place of high and low amplitude cycles. A Manchester binary 1 is equivalent to a high amplitude cycle in the AM modulation and a binary 0 indicates a low amplitude cycle. Using this modulation, an IRIG-B code "0" will be two ones followed by eight zeroes. An IRIG-B code "1" will be five ones followed by five zeroes (Figure D.1). This conversion keeps the codes compatible and makes translation or regeneration of the AM IRIG-B very simple.

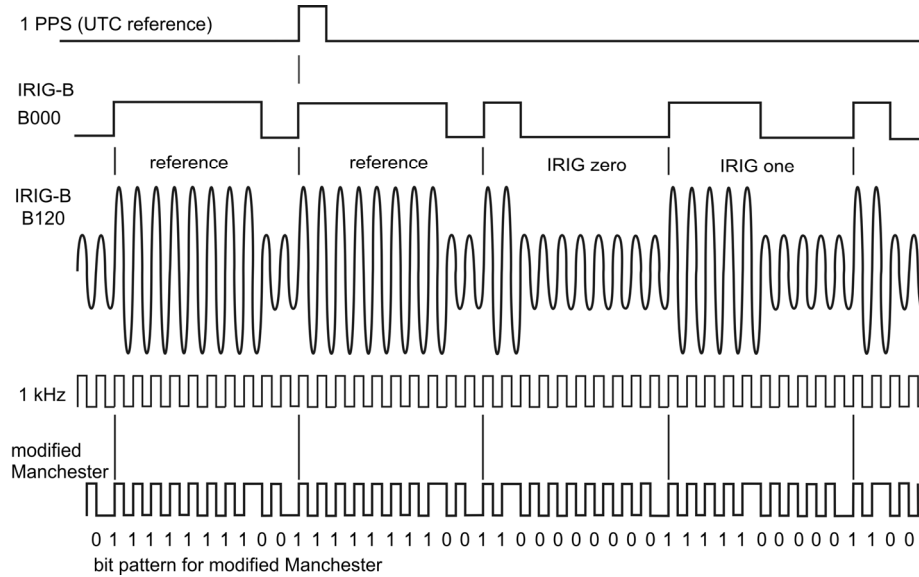

Figure D.1—IRIG-B coding comparisons: level shift, 1 kHz AM, and modified Manchester

Modified Manchester coding. Manchester modulation or encoding is a return-to-zero type where the pulse transition indicates binary 0 or 1. In this case, a 1 kHz square wave is the basic clock modulated by the data to produce a rising edge to indicate a binary one (1) and a falling edge to indicate a binary zero (0). The transition at every data bit provides good receiver synchronization. Each bit period is half high and half low, so the mean is always one-half, making it easy to decode, even at low levels. In standard Manchester coding, the data edge occurs in the middle of the clock window to indicate a binary one or zero. The “modification” moves the data window so the data is at the edge of the clock window that is on time with UTC (Figure D.2). In another view, the modification simply defines the middle of the window as “on time.” What is important is that the data edge is the on time mark in the code. This simplifies the construction of readers and regeneration of the other IRIG code forms. Modified Manchester modulation is designated type 2 in the IRIG standard (B2xx).

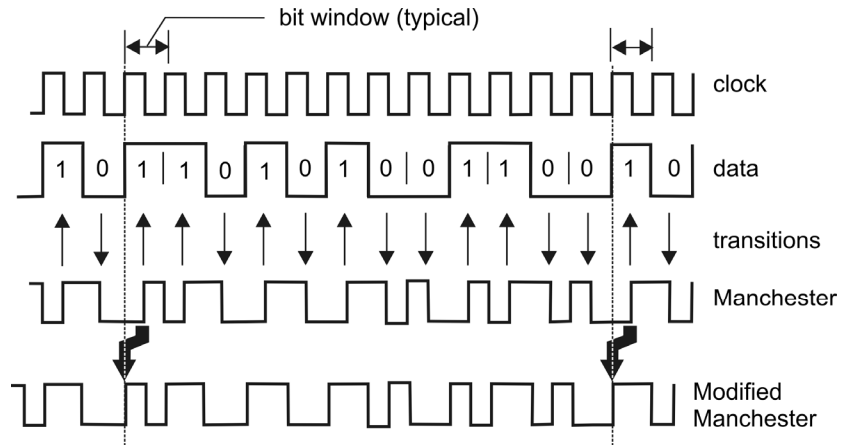

Figure D.2—Modified Manchester coding

Annex E

(informative)

TVE evaluation and PMU testing

E.1 TVE measurement technique

The total vector error (TVE) is a measure of the difference between the information from a PMU that describes a phasor and the true phasor itself.⁹ As with most measurements, the relation between the measurand and the observation is determined by calibration. It is assumed that if the error observed during calibration is within some limits of acceptability, it will remain so until the next calibration is performed, and that the measurement can therefore be “trusted.” (The behavior of systems in this regard can be used to determine an appropriate calibration interval.)

In the case of instrument transformers, applied to the metering and protective relaying of power systems, the acceptable errors are expressed (for example, in IEEE Std C57.13-2008 [B11]) separately in terms of the allowed phase angle error and the allowed magnitude error. These allowable errors are expressed, for example, in terms of *ratio correction factor*, the number by which the observation must be multiplied to obtain the true value.

To simplify compliance specification, magnitude and angle error bounds have been combined into a single error quantity called *total vector error*. This allowable error criterion combines all error sources, including time synchronization, phasor angle, and phasor magnitude estimation errors. TVE is defined by Equation (7) in 5.3.1. Since the “true” value cannot be precisely known, we rely on a calibration to establish the bounds within which the measurement (the vector) has a high probability of lying.

For calibration purposes, a signal that meets any required level of precision can be generated electronically. This standard establishes a criterion of 1% for the value of the TVE during calibration. That means that the value found by substitution into Equation (7) shall not exceed 1% if the PMU is to be deemed compliant.

The 1% criterion established by setting $TVE = 0.01$ in Equation (7) can be visualized as a small circle drawn on the end of the phasor. The maximum magnitude error is 1% when the error in phase is zero, and the maximum error in angle is just under 0.573° . Provided the observed samples do not lie outside the circle, the device is compliant. Figure E.1 shows the circle, with size greatly exaggerated for clarity.

Note that measurement of the properties of an ac signal requires some non-zero interval of observation. For an assessment of steady-state performance, the calibration signal properties will be held constant throughout the measurement interval. The observation can be compared with the input signal regardless of the measurement time.

⁹ According to the Guide to the Expression of Uncertainty in Measurements (GUM), the “true” value of a quantity (the *measurand*) is not something that can ever be known. GUM recognizes that the observer has incomplete knowledge of the measurand, and the best one can do is quantify the probability that the measurand is within a certain range of the observation. However, it will be convenient and not misleading here to use the term “true” value, so we shall continue to use it.

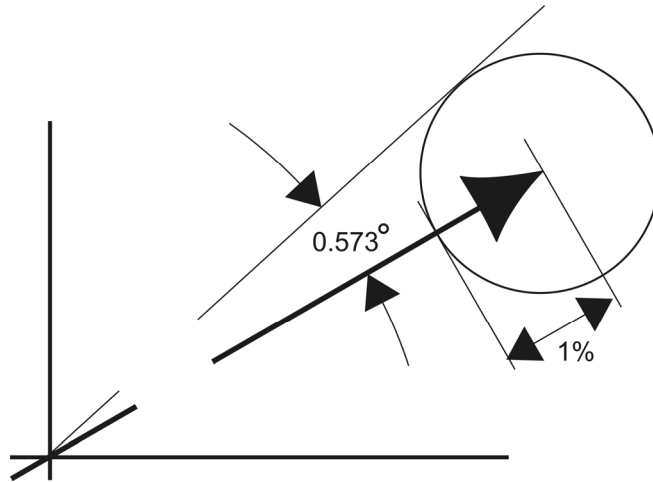

Figure E.1—The 1% TVE criterion shown on the end of a phasor

For dynamic measurement requirements, the input signal will not be a perfect sine wave, and the observation (sampling) time is important. The standard requires comparison between the input signal taken at the same time as the PMU output report. If an input signal parameter (such as phase angle) is uniformly increasing or decreasing across the measurement interval and the phasor estimator is symmetric, the estimate and the actual value will compare most closely if the measurement time is the middle of the interval.

For example, if the phase angle increases linearly from 10° to 12° across the measurement window, it will be 11° at the center. If the measurement time is the center of the window, the true value at that time is assumed to be 11° . This is therefore the value to be used during calibration to determine the TVE.

If the parameters are not constant or changing across the time window, achieving a suitable estimate of the true value becomes more difficult. If an input parameter is changing across the interval, a constant model centered on the interval will not necessarily give the best estimate. The best estimates will be achieved with a signal model that assumes the type of changes present in the time window.

However, the situation is moderated by the limited range of power system frequency response. Changes to the power signal usually occur at rates less than 3 Hz/s; where they are at a higher frequency, they are quite small. With a 1 cycle estimation window, a slower change (under 3 Hz/s) appears as short segments that are nearly linear so the center of window makes a good approximation. With higher frequencies, the magnitudes of the changes are small, so even if the time representation is not ideal, the error is small and within the TVE limit.

E.2 Phase-magnitude relation in TVE and timing

TVE combines magnitude and phase errors. While the phasor representation in Figure E.1 is straightforward to understand conceptually, it does not reveal the interaction of the two parameters in terms of their relative contribution to TVE. Figure E.2 shows the variation in TVE as a function of magnitude for various phase errors and Figure E.3 shows the variation in TVE as a function of phase for various magnitude errors. Each parameter has the same parabolic influence on the other, only differing in the intercept values for TVE.

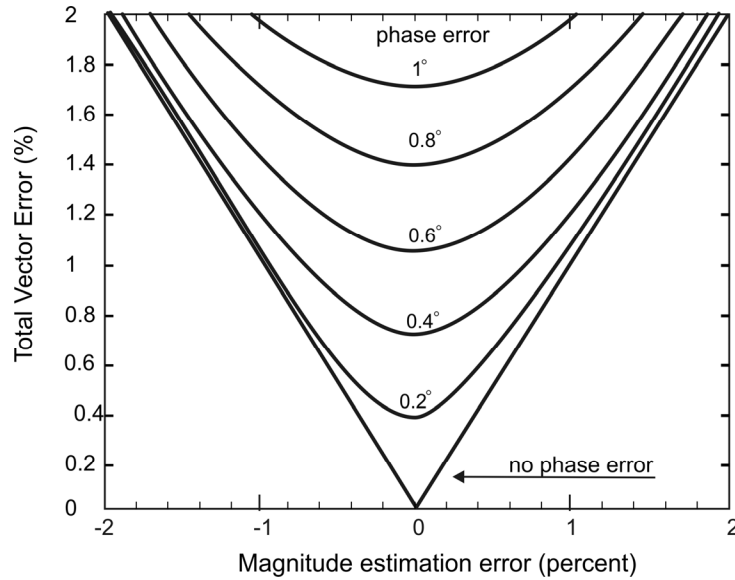

Figure E.2—TVE as a function of magnitude for various phase errors

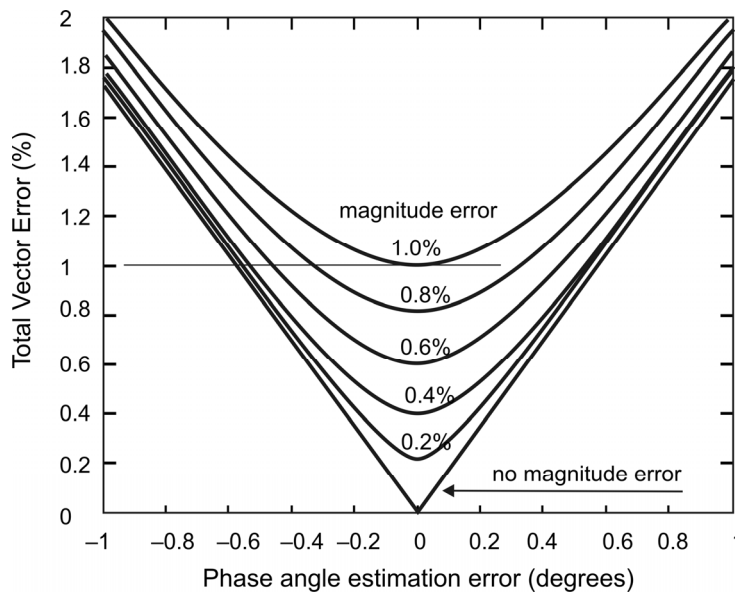

Figure E.3—TVE as a function of phase for various magnitude errors

Phase angle is determined by the relation of the given signal to a time synchronized reference at nominal system frequency. If the reference is displaced by a certain time interval, the angle of the given signal will be displaced by that same time interval, creating an error in the estimated phase angle. Thus timing errors translate directly to phase errors. The TVE is computed relative to measurement magnitude and phase at the given system frequency. Consequently timing errors will result in different TVE depending on system frequency. A cycle at system frequency is 20 ms at 50 Hz and 16.67 ms at 60 Hz. One degree of phase angle at 50 Hz is 55.6 μ s and at 60 Hz is 46.3 μ s. Therefore the timing error that will cause a 1% TVE error at 50 Hz is ± 31.7 μ s and at 60 Hz is ± 26 μ s.

E.3 Testing

Testing requires confirming the measurement from a PMU matches the input signal. A signal with parameters matching a particular phasor specification is applied to the PMU input. The phasor, frequency, and ROCOF measurements (estimates) output from the PMU are then compared with the input using the TVE, FE, and RFE criteria. The comparison is done between the phasor, frequency, and ROCOF values of the input at the exact time that matches the measurement output time stamp. Since the output measurement time is synchronized to UTC time, the signal provided at the input must also be UTC synchronized (to determine the values for comparison). Signal generators are available that provide precise phase angle, magnitude, and frequency settings that are GPS synchronized. Complete test procedures are being produced by IEEE and other organizations. They are not part of this standard.

Refer to *Evaluation of measurement data—Guide to the expression of uncertainty in measurement*, JCGM 100:2008 (GUM 1995 with minor corrections).¹⁰

¹⁰ Available from <http://www.bipm.org/en/publications/guides/gum.html> (accessed January 26, 2011).

Annex F

(informative)

Generator voltage and power angle measurement¹¹

F.1 Introduction

The synchronized and near real-time acquisition of signals relevant to the dynamic performance of power systems provides a basis for the dynamic monitoring, control, and protection of these systems over wide areas. Synchronized estimation of voltage and current phasors are an important set of signals required to track the dynamic performance of power systems. However, there are a number of other relevant signals, including the rotor-angle, power angle, and rotor-speed of synchronous machines.

Although the acquisition of these other signals is beyond the scope of this standard, this annex is provided to indicate a way phasor measurement can be used with other measurement techniques for future development of synchronized measurements for power systems.

F.2 Measurement methods

- a) *Electrical calculation method:* The internal voltage and the power angle of a generator can be derived from knowledge of the direct-axis reactance X_d , the quadrature-axis reactance X_q , and real-time PMU or Supervisory Control and Data Acquisition (SCADA) data measurements representing the terminal voltage and current. This method may lead to errors because the values of X_d and X_q might vary with the generator operating conditions.
- b) *Rotor position measurement method:* The angle of internal voltage and the power angle of a generator can be calibrated against the rotor position and the terminal voltage angle. This method has good accuracy and is suitable for real-time power angle measurement when the power system is subject to a disturbance. The rotor position measurement method may be therefore considered advantageous for measurement of the generator power angle and frequency.

F.3 Input signal

For measurements of internal voltage and power angles, the input signals to the PMU include the terminal voltages and currents of the generator, and a signal representing the rotor position, all with respect to the same time reference.

F.4 Measuring process

The rotor position of a generator may be monitored by optical or magnetic means. In the optical method, some kind of shaft encoder can be used. In the magnetic method, a periodic pulse signal may be produced by a slot added for the purpose at some arbitrary location on the rotor, and a sensor on the stator. By comparing the rotor position signal with the reference time signal, the rotor position angle (called α) of the generator can be calculated. When the generator runs with no load, the power angle of the generator is zero, and any offset between the rotor position signal and the internal voltage angle can be calibrated as follows.

¹¹ The concept and basis for this annex has been kindly contributed by the WAMS & Time Synchronization Working Group of SAC 82, Beijing, China. See Synchrophasor Measurement Standard [B12].

Under no-load conditions, the voltage angle at the terminals of the generator is the same as the angle of the internal voltage angle of the generator. Measured relative to the reference time signal, the angle of the terminal voltage under no-load is indicated as angle β in Figure F.1. The rotor position, which depends on the position of shaft encoder or the slot on the rotor of the generator, is at some angle α . The angular offset (γ) between the angles α and β can be obtained. This angle γ remains constant unless something in the physical machine is changed; for example, the coil assembly is rebuilt during maintenance.

Thus the angle γ does not change when the machine is under load. Therefore, when the generator is operating, the angle of the internal voltage can be calculated from knowledge of the rotor angle and the calibration offset γ . See Figure F.2. The voltage angle β is found by subtracting γ from α (which is observable). The generator power angle δ is then given by the difference between the internal voltage angle β and the terminal voltage of the generator, as shown in Figure F.2.

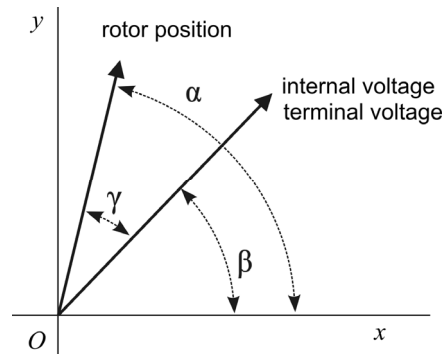

Figure F.1—Phasor diagram under no-load conditions

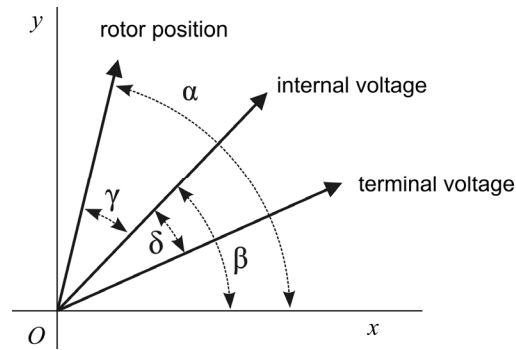

Figure F.2—Phasor diagram with load on generator